

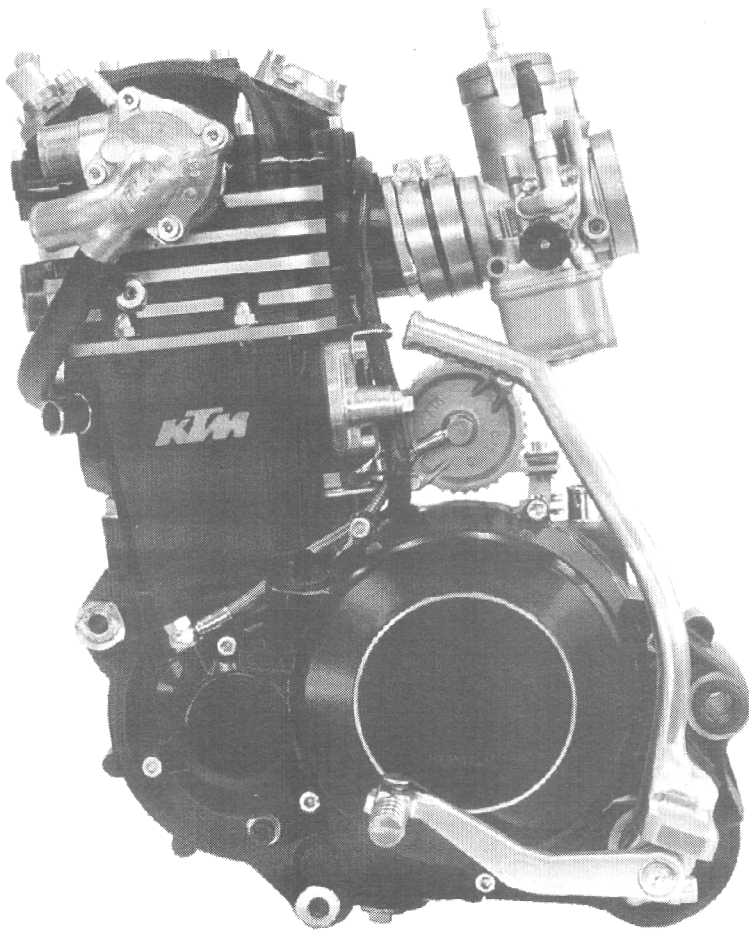

ERSATZTEILKATALOG

MOTOR 350/400/620

Technische Daten



LC4

'94

SPARE PARTS MANUAL

ENGINE 350/400/620

Technical Data

ART. NR. 3.203.68

1.94

MOTERGEHÄUSE
CRANK CASE

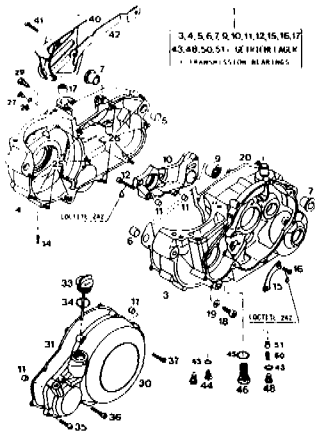

SEITE
Page
3

KURBELWELLE, KOLBEN
CRANKSHAFT, PISTON

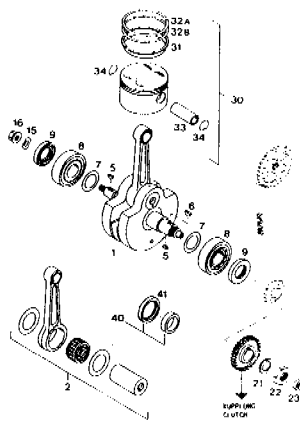

SEITE
Page
4

ZYLINDER
CYLINDER

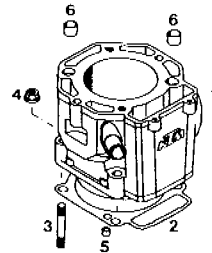

SEITE
Page
5

ZYLINDERKOPF
CYLINDER HEAD

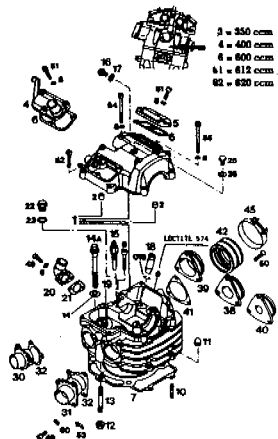

SEITE
Page
5-6

VENTILTRIEB
VALVE DRIVE

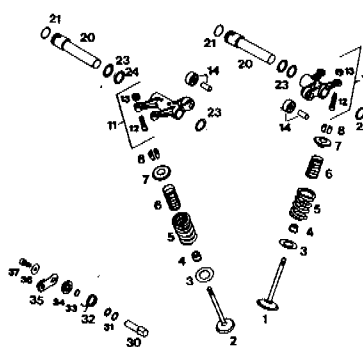

SEITE
Page
7

STEUERTRIEB
TIMING DRIVE

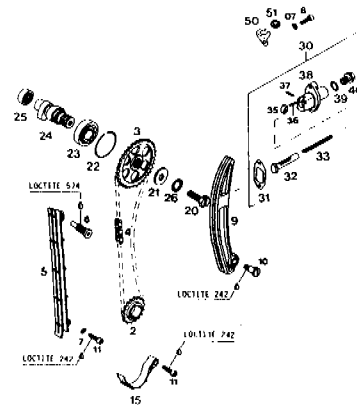

SEITE
Page
8

SCHMIERSYSTEM 400 EXC USA
LUBRICATION SYSTEM

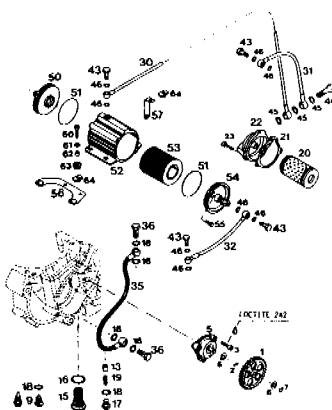

SEITE
Page
9

SCHMIERSYSTEM SX, EXC
LUBRICATION SYSTEM

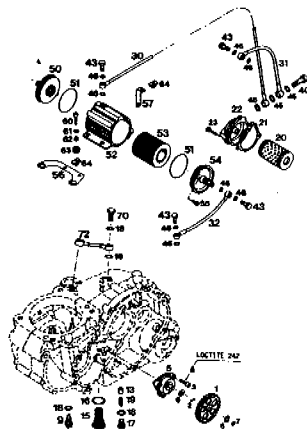

SEITE
Page
10

SCHMIERSYSTEM EXC, EGS, RXC
LUBRICATION SYSTEM

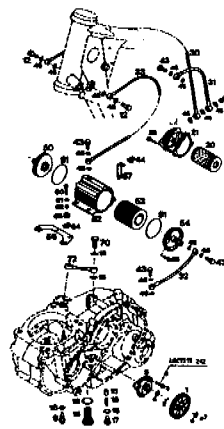

SEITE
Page
11

MOTORENTLÜFTUNG
BREATHER SYSTEM

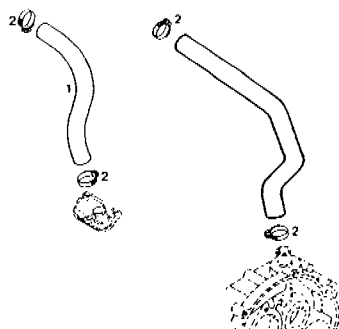

SEITE
Page
12

VERGASER PHBE 36 HD
CARBURETTOR

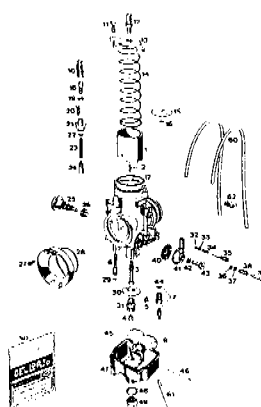

SEITE
Page
12-13

VERGASER PHM 38 SD, PHM 40 SD
CARBURETTOR

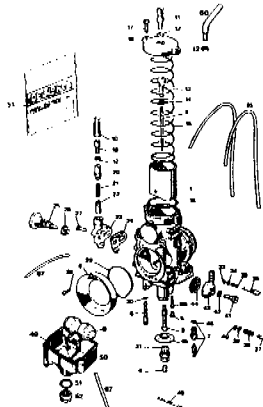

SEITE
Page
14-15

94-583.30.0 MOTORGEHÄUSE 350-620 LC4 '94
CRANK CASE

BILD FIG.	TEILENUMMER PART NUMBER	BEZEICHUNG DESCRIPTION	STK. QTY.
1*	580.30.000.944	MOTORGEHÄUSE KPL.M.GETR.LAG'94 ENGINE CASE	1
5	501.30.027.000	PASSHÜLSE 19 X 15,5 X 12 DOWEL	1
6	510.30.026.100	PASSHÜLSE 17 X 14 X 12 DOWEL	1
7	501.30.010.000	GEHÄUSEBÜCHSE CRANK CASE BUSH	2
9	580.33.097.000	NADELLAGER HK 2216 KSE NEEDLE BEARING	1
10*	580.30.011.600	SCHALTUNGSTRÄGER SHIFTING M. SUPP.	'94 1
11	490.30.090.000	PASSHÜLSE 7 X 9,8 X 10 DOWEL	4
12	0912 060403	ISK-SCHRAUBE DIN912-M6X40 A H SCREW	2
12	0912 060353	ISK-SCHRAUBE DIN912-M6X35 A H BOLT	1
14	491.30.450.050	DORNPROFIL LW 3 TUBE	1
15	565.30.017.000	HALTEBLECH RETAINING PLATE	1
16	0991 060163	ISK-SENKSCHRAUBE DIN7991-M6X16 COUNTERSUNK SCREW	2
17	503.32.095.000	NADELHÜLSE HK 1212 NEEDLE CAGE	2
18*	580.30.080.000	FIXIERSCHRAUBE M8 LOCATING BOLT	1
19*	580.30.081.000	CU-DICHTRING 8 X 14 X 3 SEAL RING	1
20	580.30.039.000	GEHÄUSEDICHTUNG ENGINE CASE GASKET	1
25	0912 060553	ISK-SCHRAUBE DIN912-M6X55 A H BOLT	6
26	0912 060303	ISK-SCHRAUBE DIN912-M6X30 A H SCREW	5
27	490.30.029.000	ÖLABLASSSCHRAUBE ISK M10X10 OIL DRAIN PLUG	X
28	580.38.032.010	DICHTRING 10 X 14 X 1 CU SEAL RING	X
29	6 241 850	KONTAKTSCHRAUBE M10 CONTACT SCREW	1
30	580.30.001.200	KUPPLUNGSDECKEL KPL.SCHWARZ'93 CLUTCH COVER BLACK	1
31	580.30.025.000	KUPPLUNGSDECKELDICHTUNG CLUTCH COV.GASKET	1
33	580.30.020.044	ÖLEINFÜLLSCHRAUBE PLUG	1
34	0770 160030	O-RING 16 X 3 O-RING	1
35	0912 060253	ISK-SCHRAUBE DIN912-M6X25 A H SCREW	5
36	0912 060303	ISK-SCHRAUBE DIN912-M6X30 A H SCREW	1
37	0984 060252	ISK-SCHRAUBE DIN7984-M6X25 A H BOLT	2



BILD FIG.	TEILENUMMER PART NUMBER	BEZEICHUNG DESCRIPTION	STK. QTY.
40	580.30.050.600	KETTENABDECKUNG SCHWARZ SPROCKET COVER	'91 1
41	0912 060303	ISK-SCHRAUBE DIN912-M6X30 A H SCREW	2
42	580.30.047.515	KETTENDÄMPFUNGSBLECH LC4 CHAIN DAMPER SHEET	'90 1
43	580.38.022.000	DICHTRING 12 X 18 X 1,5 CU SEAL RING	2
44	580.38.020.000	ÖLABLASSSCHRAUBE MIT MAGNET M12 OIL DRAIN PLUG	1
45	580.38.017.000	DICHTRING 22 X 27 X 1 CU SEAL RING	1
46	580.38.019.000	ÖLVERSCHLUSSSCHRAUBE M22X1,5 OIL DRAIN PLUG	1
48	0908 120153	VERSCHLUSSSCHRAUBE M12X1,5 PLUG	1
50	580.38.023.300	DRUCKFEDER L=25MM D=1MM SPRING	1
51	580.38.028.000	VENTILKOLBEN D=10MM VALVE PISTON	1
--	575.30.100.000	DICHTUNGSSATZ 350/500 LC4 GASKET SET	1
--	580.30.100.000	DICHTUNGSSATZ 400/600 LC4 GASKET SET	1
--	580.30.900.000	DICHTUNGSSATZ 612/620 LC4 GASKET SET	1

* = NEUTEILE / NEW PARTS

X = NACH BEDARF / AS REQUIRED

94-583.30.1 KURBELWELLE, KOLBEN 350-620 LC4
CRANKSHAFT, PISTON

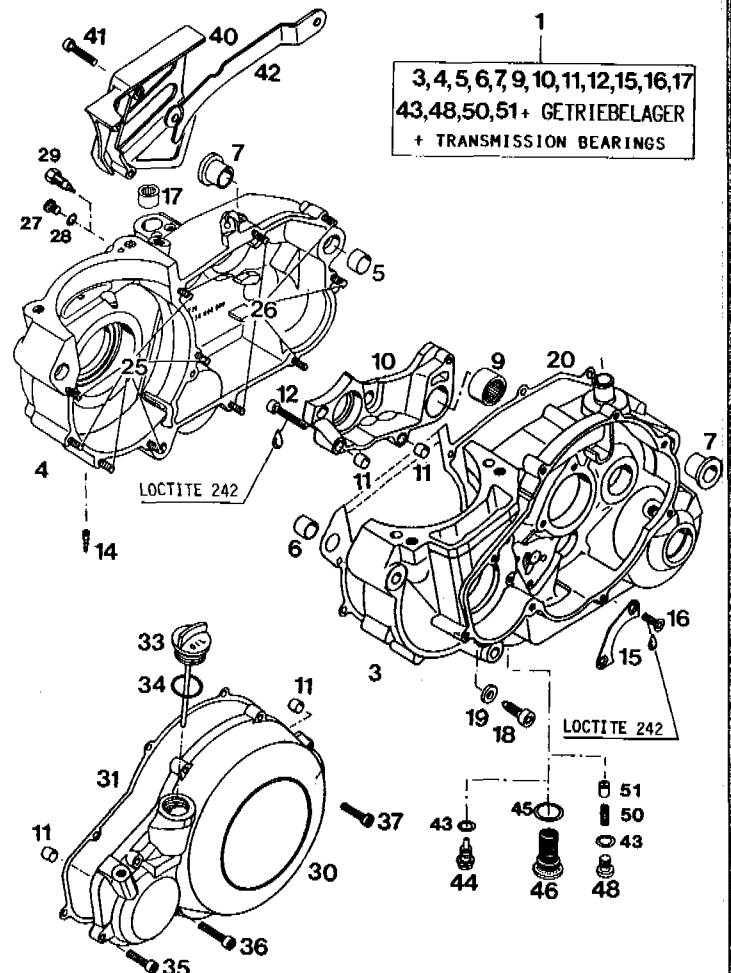
BILD FIG.	TEILENUMMER PART NUMBER	BEZEICHUNG DESCRIPTION	STK. QTY.
1	575.30.018.000	KURBELWELLE KPL. HUB 56,2MM '93 CRANKSHAFT CPL. 350/400 LC4 '93	1
1*	583.30.018.000	KURBELWELLE KPL. HUB 76MM '94 CRANKSHAFT CPL. 620 LC4 '94	1
2	580.30.015.044	PLEUEL-REP.SATZ LC4 CON.ROD REPAIR KIT 350/400/500/612 CC, L=140MM	1
2*	583.30.015.044	PLEUEL-REP.SATZ LC4 CON.ROD REPAIR KIT 620 CC, L=141,5MM	1
5	0888 030050	SCHEIBENFEDER DIN6888-3X5 WOODRUFF KEY	2
6	0888 050650	SCHEIBENFEDER DIN6888-5X6,5 WOODRUFF KEY	1
7	560.30.081.000	PASSSCHEIBE 30 X 42 X 0,1 SHIM	X
7	560.30.081.100	PASSSCHEIBE 30 X 42 X 0,15 SHIM	X
7	560.30.081.200	PASSSCHEIBE 30 X 42 X 0,3 SHIM	X
8	580.30.082.000	ZYLINDERROLLENLAGER NJ 306 ROLLER BEARING	2
9	0760 305272	WELLENDICHRING 30X52X7BTSL RADIAL SEAL RING	2
15	0137 120000	FEDERSCHEIBE DIN137-B12 SPRING WASHER	1
16	510.30.028.100	BUNDMUTTER M12X1 LINKS MAGNETO NUT	1
21	580.30.019.000	SPERRKANTRING VSK 20 LOCKING RING	1
22	0936 200155	SK-MUTTER DIN936-M20X1,5 H H NUT	1
23	0760 122270	WELLENDICHRING 12 X 22 X 7 B SEAL RING	1
30	575.30.007.000	KOLBEN 89 MM KPL. (EK2033) '93 PISTON CPL. 350 LC4	1
30	576.30.007.000	KOLBEN 95 MM KPL. (EK2074) '93 PISTON CPL. 400/600 LC4	1
30*	583.30.007.000	KOLBEN 101 MM KPL. (EK1895)'94 PISTON CPL. 620 LC4	1
31	575.30.031.000	ÖLABSTREIFRING 89 MM 350 LC4 OIL STRAINER RING	1
31	580.30.631.000	ÖLABSTREIFR. 95MM 400/600 LC4 OIL STRAINER RING	1
31*	583.30.831.000	ÖLABSTREIFRING 101 MM 620 LC4 OIL STRAINER RING	1
32A	575.30.032.000	RECHTECKRING 89 MM 350 LC4 SQUARE RING	1
32A	580.30.632.000	RECHTECKRING 95 MM 400/600 LC4 SQUARE RING	1
32A*	583.30.832.000	RECHTECKRING 101 MM 620 LC4 SQUARE RING	1



BILD FIG.	TEILENUMMER PART NUMBER	BEZEICHUNG DESCRIPTION	STK. QTY.
32B	575.30.132.000	MINUTENRING 89 MM 350 LC4 RECTANGULAR RING	1
32B	580.30.732.000	MINUTENRING 95 MM 400/600 LC4 RECTANGULAR RING	1
32B*	583.30.932.000	MINUTENRING 101MM 620 LC4 RECTANGULAR RING	1
33	580.30.033.000	KOLBENBOLZEN 22 X 13 X 54,2 PISTON PIN 350/400/600 LC4	1
33*	583.30.833.000	KOLBENBOLZEN 22 X 13 X 60 PISTON PIN 620 LC4	1
34	580.30.074.000	DRAHTSPRENGRING A 22 X 1,5 CIRCLIP 350/400/600/620 LC4	2
40*	580.30.018.090	KURBELW. REP. RING 30X38X9,5 REP. SEAL RING FÜR REP.SATZ KURBELW.SIMMERING	X
41	0760 385273	WELLENDICHRING 38X52X7 BTSL RADIAL SEAL RING FÜR REP.SATZ KURBELW.SIMMERING	X

* = NEUTEILE / NEW PARTS

X = NACH BEDARF / AS REQUIRED

94-583.30.2 ZYLINDER 350-620 LC4'94
CYLINDER

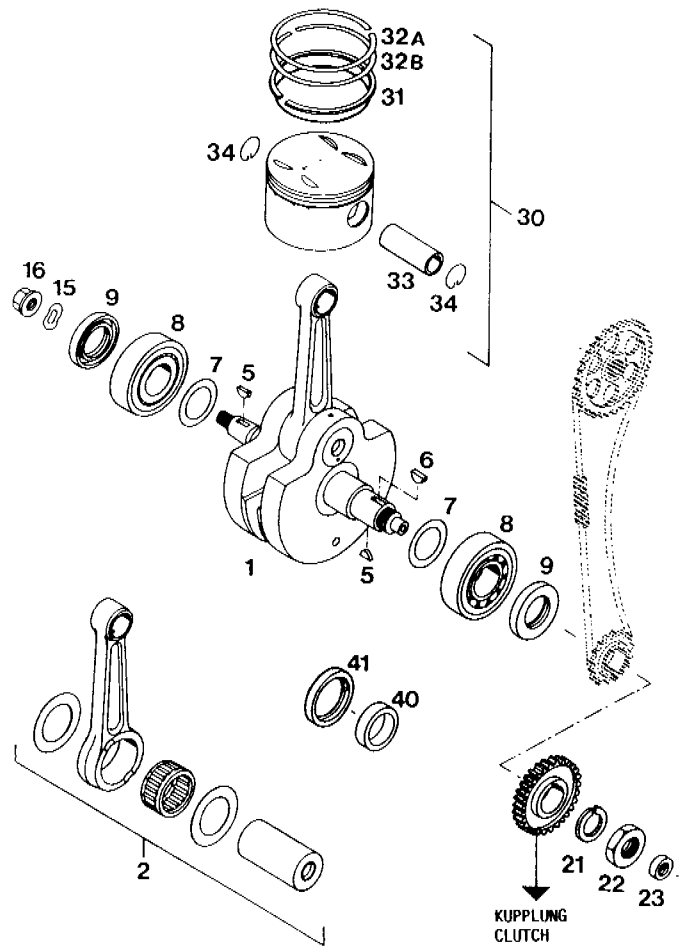
BILD FIG.	TEILENUMMER PART NUMBER	BEZEICHNUNG DESCRIPTION	STK. QTY.
1	575.30.005.000	ZYLINDER 89 MM CYLINDER	350 LC4'93 1
1	576.30.005.000	ZYLINDER 95 MM CYLINDER	400 LC4'93 1
1*	583.30.005.000	ZYLINDER 101 MM CYLINDER	620 LC4'94 1
2	580.30.030.000	ZYLINDERFUSSDICHTUNG CYL. BASE GASKET	1
3	0835 100451	STIFTSCHR. DIN835-M10X45-10.9 STUD	4
4	0331 100003	BUNDMUTTER M10 SW15 NUT	4
5	490.30.090.000	PASSHÜLSE 7 X 9,8 X 10 DOWEL	2
6	510.30.026.100	PASSHÜLSE 17 X 14 X 12 DOWEL	2

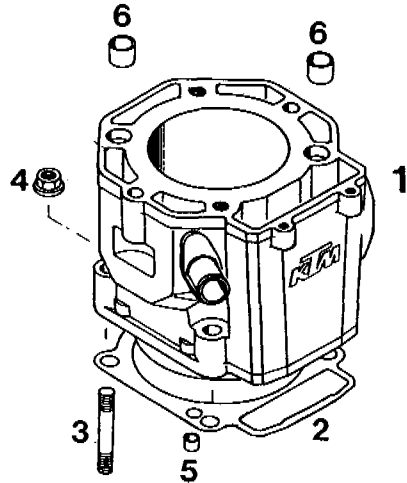

* = NEUTEILE / NEW PARTS X = NACH BEDARF / AS REQUIRED

94-583.36.1 ZYLINDERKOPF 350-620 LC4'94
CYLINDER HEAD

BILD FIG.	TEILENUMMER PART NUMBER	BEZEICHNUNG DESCRIPTION	STK. QTY.
1	575.36.020.044	ZYLINDERKOPF KPL. CYLINDER HEAD CPL.	350 LC4'93 1
1	576.36.020.044	ZYLINDERKOPF KPL. CYLINDER HEAD CPL.	400 LC4'93 1
1*	583.36.020.044	ZYLINDERKOPF KPL. CYLINDER HEAD CPL.	620 LC4'94 1
2	490.30.090.000	PASSHÜLSE 7 X 9,8 X 10 DOWEL	2
4	580.36.152.500	VENTILDECKEL VORNE MOD '90 VALVE COVER FRONT	1
5	580.36.052.000	VENTILDECKEL VALVE COVER	1
6	580.36.053.000	VENTILDECKELDICHUNG VALVE COVER GASKET	2
7	575.30.036.000	ZYLINDERKOPFDICHTUNG 90,3 MM CYL.HEAD GASKET 350/500 LC4	1
7	580.30.136.200	ZYLINDERKOPFDICHTUNG 95,3 MM CYL.HEAD GASKET 400/600 LC4	1
7	583.30.036.000	ZYLINDERKOPFDICHTUNG 101,3 MM CYL.HEAD GASKET 612/620 LC4	1
8	580.36.065.000	DICHTRING 6 X 10 X 1 CU SEAL RING	10
9*	0912 060353	ISK-SCHRAUBE DIN912-M6X35 A H BOLT	1
10	0551 060253	GEWINDESTIFT DIN551-M6X25 STUD	2
10	0551 060303	GEWINDESTIFT DIN551-M6X30 STUD	2

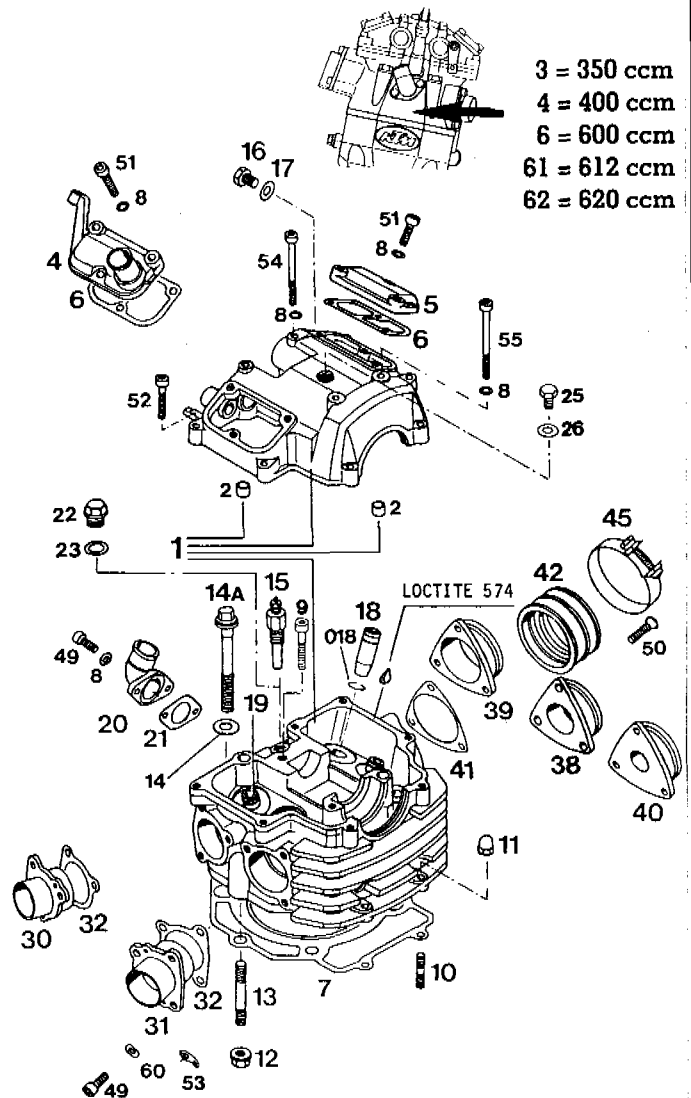

3 = 350 ccm
4 = 400 ccm
6 = 600 ccm
61 = 612 ccm
62 = 620 ccm

94-583.36.1 ZYLINDERKOPF 350-620 LC4'94
CYLINDER HEAD

BILD FIG.	TEILENUMMER PART NUMBER	BEZEICHNUNG DESCRIPTION	STK. QTY.
11	0587 060003	SK-HUTMUTTER DIN1587-M6 HEX NUT	2
12	490.30.028.000	BUNDMUTTER M8 - 8MM HOCH FLANGE NUT	2
13	543.30.043.100	STIFTSCHRAUBE M8X35 STUD	2
13	543.30.043.000	350/400 LC4 STIFTSCHRAUBE M8X40 STUD	2
14	580.36.098.000	CU-DICHTRING 10 X 20 X 1 SEAL RING	4
14A	580.36.099.100	BUNDSCHRAUBE M10X80 SK13MM FLANGE SCREW	4
15	420.11.252.000	TEMPERATURSCHALTER VDO TEMP. INDICATOR	1
16	0933 080123	SK-SCHRAUBE DIN933-M8X12 H H SCREW	1
17	580.38.032.000	DICHTRING 8,2 X 12 X 0,8 SEAL RING-CU	1
018	0993 012000	SPRENGRING DIN7993A-RW12 CIRCLIP	4
18	580.36.026.600	VENTILFÜHRUNG EINLASS VALVE GUIDE INTAKE	'91 2
19	580.36.126.600	VENTILFÜHRUNG AUSLASS VALVE GUIDE EXHAUS	'91 2
20	565.35.006.000	WINKELSTUTZEN CONNECTING TUBE	1
21	565.35.106.000	DICHTUNG FÜR WINKELSTUTZEN GASKET	1
22*	0908 100003	SK-VERSCHLUSSSCHRAUBE M10X1 H H COLLAR SCREW	1
23	580.38.032.010	DICHTRING 10 X 14 X 1 SEAL RING	1
25	0933 080103	SK-SCHRAUBE DIN933-M8X10 SCREW M 8X10	1
26	580.38.032.000	DICHTRING 8,2 X 12 X 0,8 SEAL RING-CU	1
30	580.36.040.000	AUSPUFFFLANSCH RECHTS EXHAUST FLANGE R/S	1
31	580.36.140.000	AUSPUFFFLANSCH LINKS EXHAUST FLANGE L/S	1
32	580.36.041.000	AUSPUFFFLANSCHDICHTUNG EXH.FLANGE GASKET	2
38*	581.36.142.026	ANSAUGSTUTZEN D=26MM INTAKE FLANGE	1
38*	581.36.142.028	620 EGS CH ANSAUGSTUTZEN D=28MM INTAKE FLANGE	1
39	575.36.042.000	350 EXC SUPERC., 400 EGS / BRD 620 EXC/SUPERC. BRD, 620 EGS F ANSAUGSTUTZEN D=37MM INTAKE FLANGE	1
39	581.36.042.000	350 LC4 ANSAUGSTUTZEN D=38MM INTAKE FLANGE	1

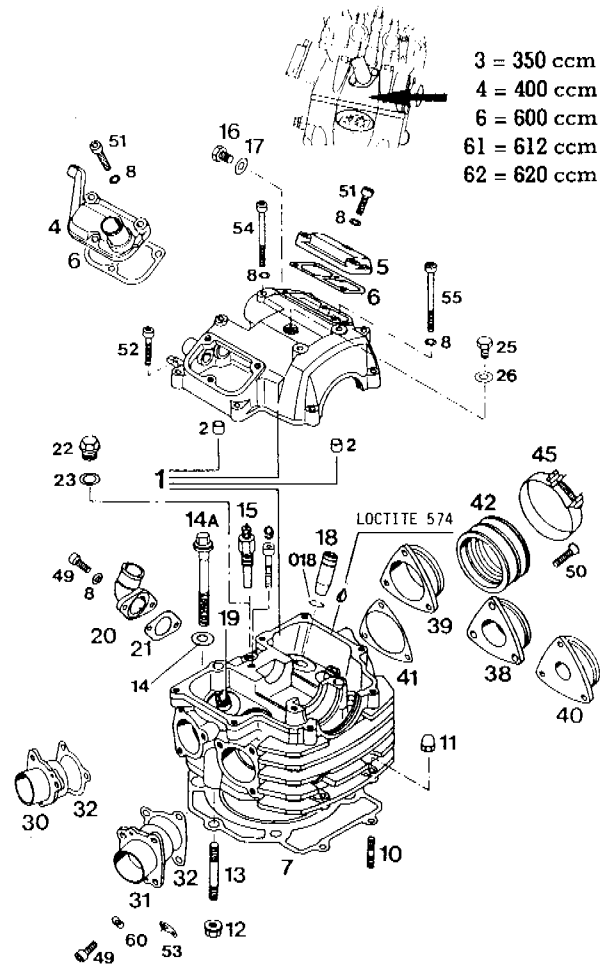

3 = 350 ccm
4 = 400 ccm
6 = 600 ccm
61 = 612 ccm
62 = 620 ccm

40	581.36.142.023	ANSAUGSTUTZEN D=23,5MM INTAKE FLANGE	1
41	581.36.043.000	400 EXC BRD, 400 EGS A,F 400 EGS CH ANSAUGSTUTZENDICHTUNG GASKET	1
42	575.36.044.000	GUMMIMUFFE D=37MM RUBBER	350 LC4 1
42	581.36.044.100	GUMMIMUFFE D=38MM RUBBER	400-620 LC4 1
45	565.30.061.000	SCHELLE 60/12 CLAMP	2
49	0912 060163	ISK-SCHRAUBE DIN912-M6X16 A H SCREW	8
50	0991 060163	ISK-SENKSCHRAUBE DIN7991-M6X16 COUNTERSUNK SCREW	3
51	0912 060203	ISK-SCHRAUBE DIN912-M6X20 A H SCREW	6
52	0912 060253	ISK-SCHRAUBE DIN912-M6X25 A H SCREW	6
52	0912 060353	ISK-SCHRAUBE DIN912-M6X35 A H BOLT	1
53	510.05.074.000	FEDERLASCHE RETAINING PLATE	2
54	0912 060603	ISK-SCHRAUBE DIN912-M6X60 A H BOLT	2
55	0912 060703	ISK-SCHRAUBE DIN912-M6X70 A H BOLT	2
60	0137 060000	FEDERSCHEIBE DIN137-B6 SPRING WASHER	6

* = NEUTEILE / NEW PARTS

X = NACH BEDARF / AS REQUIRED

93-580.36.2

VENTILTRIEB
VALVE DRIVE

LC4'93

BILD FIG.	TEILENUMMER PART NUMBER	BEZEICHNUNG DESCRIPTION	STK. QTY.
1	580.36.030.000	EINLASSVENTIL 36 MM INTAKE VALVE	2
2	580.36.031.000	AUSLASSVENTIL 30 MM EXHAUST VALVE	2
3	580.36.027.100	ANLAUFSCHEIBE 12,2X29,5X0,5 THRUST WASHER	4
4	580.36.028.000	VENTILSCHAFTDICHTUNG SEAL FOR VALVE	4
5	580.36.029.100	VENTILFEDER AUSSEN OUTER VALVE SPRING	4
6	580.36.129.100	VENTILFEDER INNEN INNER VALVE SPRING	4
7	580.36.032.600	VENTILFEDERTELLER ALU SPRING RETAINER	4
8	580.36.033.000	VENTILKEGELSTÜCK MK7 KEY HALF	8
10	580.36.060.644	KIPPEBEL EINLASS KPL. ROCKER ARM INTAKE	1
11	580.36.061.644	KIPPEBEL AUSLASS KPL. ROCKER ARM EXHAUST	1
12	580.36.062.600	EINSTELLSCHRAUBE M7X0,75 '91 ADJUSTMENT SCREW	4
12	580.36.062.000	EINSTELLSCHRAUBE M7 ADJUSTMENT SCREW	X
13	0934 070756	SK-MUTTER DIN934-M7X0,75-10.9 HEX NUT	4
14	580.36.061.090	KIPPEBELROLLE KPL. ROCKER ARM ROLLER	2
20	580.36.056.100	KIPPEBELWELLE L=96MM ROCKER ARM SHAFT	2
21	580.36.095.000	O-RING 15,08 X 2,62 O-RING	2
23	0988 162210	PASSSCHEIBE 16 X 22 X 1 SHIM WASHER	X
24	0988 162205	PASSSCHEIBE 16 X 22 X 0,5 SHIM WASHER	X
30	580.36.050.100	DEKO-WELLE DECOMPR. SHAFT	1
31	543.34.015.000	ST-SCHEIBE 10 X 14 X 0,5 FLAT WASHER	X
31	543.34.015.100	ST-SCHEIBE 10 X 14 X 0,3 WASHER	X
31	543.34.015.200	ST-SCHEIBE 10 X 14 X 0,15 WASHER	X
32	580.36.059.200	DEKO-HEBELFEDER 1,8 MM SPRING	1
33	0770 100221	O-RING 10 X 2,2 SILICON O-RING	1
34	580.36.048.000	ABDECKSCHEIBE COVER	1
35	580.36.049.500	DEKO-WELLENHEBEL DECOMPR. LEVER	1
36	0021 060003	SCHEIBE DIN9021-A6,4 FLAT WASHER	1
37	0912 060103	ISK-SCHRAUBE DIN912-M6X10 A H SCREW	1

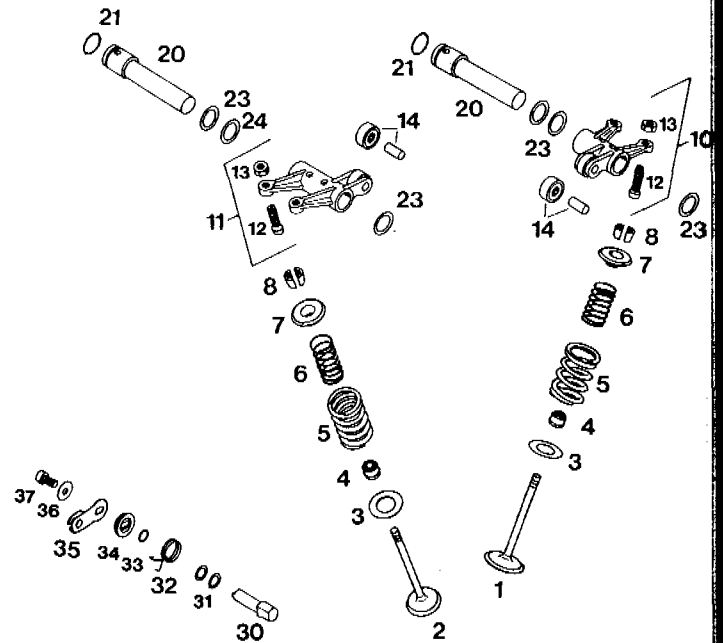

* = NEUTEILE / NEW PARTS

X = NACH BEDARF / AS REQUIRED

94-583.36.0 STEUERTRIEB 350-620 LC4'94
TIMING DRIVE

BILD FIG.	TEILENUMMER PART NUMBER	BEZEICHNUNG DESCRIPTION	STK. QTY.
2	580.36.014.000	STEUERRITZEL 17-Z TIMING SPROCKET	1
3	580.36.011.000	NOCKENWELLENRAD 34-Z TIMING SPROCKET	1
3*	583.36.011.001	NOCKENWELLENRAD 34-Z TIMING SPROCKET	'94 1
4	575.36.013.000	STEUERKETTE C107C / 96 ROLLEN TIMING CHAIN	1
4	580.36.013.000	STEUERKETTE C107C / 100 ROLLEN TIMING CHAIN	1
5	575.36.001.000	STEUERKETTENFÜHRUNG TIMING CHAIN GUIDE	1
5	580.36.001.000	STEUERKETTENFÜHRUNG TIMING CHAIN GUIDE	1
6	580.36.009.000	KETTENFÜHRUNGSSCHRAUBE CHAIN GUIDE BOLT	1
07	580.36.065.000	DICHTRING 6 X 10 X 1 CU SEAL RING	2
7	0137 060000	FEDERSCHEIBE DIN137-B6 SPRING WASHER	1
8	0912 060203	ISK-SCHRAUBE DIN912-M6X20 A H SCREW	2
9	575.36.002.000	STEUERKETTENSPIANNER CHAIN TENSIONER	1
9	580.36.002.000	STEUERKETTENSPIANNER CHAIN TENSIONER	1
10	0923 080120	FLACHKOPFSCHRAUBE M 8 X 12 FLAT HEAD SCREW	1
11	0912 060208	ISK-SCHRAUBE DIN912-M6X20 SS A H SCREW S LOCK.	2
15	580.36.018.000	AUSFALLSICHERUNG SECURING GUIDE	1
20	580.36.112.500	SECHSKANTSCHRAUBE M10X30 HEX HEAD BOLT	1
21	580.36.012.000	SCHLEIBE 10 X 25 X 2 GEHÄRTET WASHER	1
22	580.36.096.000	SPRENGRING SB 42 CIRCLIP	1
23	0625 060040	RILLENKUGELLAGER 6004 C3 KSE BEARING	1
24	575.36.010.000	NOCKENWELLE 995 350/400 CAM SHAFT	1
24	580.36.010.000	NOCKENWELLE 249 600/612/620 CAM SHAFT	1
25	580.36.097.000	NADELBUCHSE BK 2012 NEEDLE BEARING	1
26	360.03.014.200	SCHNORR-SICHERUNGSSCHLEIBE 10MM LOCKING WASHER	1
30	580.36.003.144	AUTOMATIKSPIANNER KPL. '88 AUTOM. TENSIONER CP	1



BILD FIG.	TEILENUMMER PART NUMBER	BEZEICHNUNG DESCRIPTION	STK. QTY.
31	580.36.005.100	SPANNERDICHTUNG 1,5 MM GASKET	1
32	580.36.004.100	DRUCKBOLZEN PRESSURE BOLT	1
33	580.36.006.100	DRUCKFEDER 0,9 MM SPRING	1
35	580.36.007.100	KLINKE LOCKING PIECE	1
36	580.36.007.050	DRUCKFEDER F. KLINKE SPRING	1
37	0402 031780	LAGERNADEL 3 X 17,8 NEEDLE	1
38	580.36.003.100	SPANNERGEHÄUSE TENSIONER CASE	1
39	580.38.022.000	DICHTRING 12 X 18 X 1,5 CU SEAL RING	1
40	580.36.008.100	VERSCHLUSSSCHRAUBE M 12 X 1,5 PLUG	2
50	580.38.339.000	HALTERUNG F. ZÜNDKABEL RETAINING PLATE	1
51	310.11.027.000	KABELTÜLLE (INNENDURCHM. 10MM) RUBBER SLEEVE	1

* = NEUTEILE / NEW PARTS

X = NACH BEDARF / AS REQUIRED

94-583.38.0 SCHMIERSYSTEM 400 EXC USA '94
LUBRICATION SYSTEM

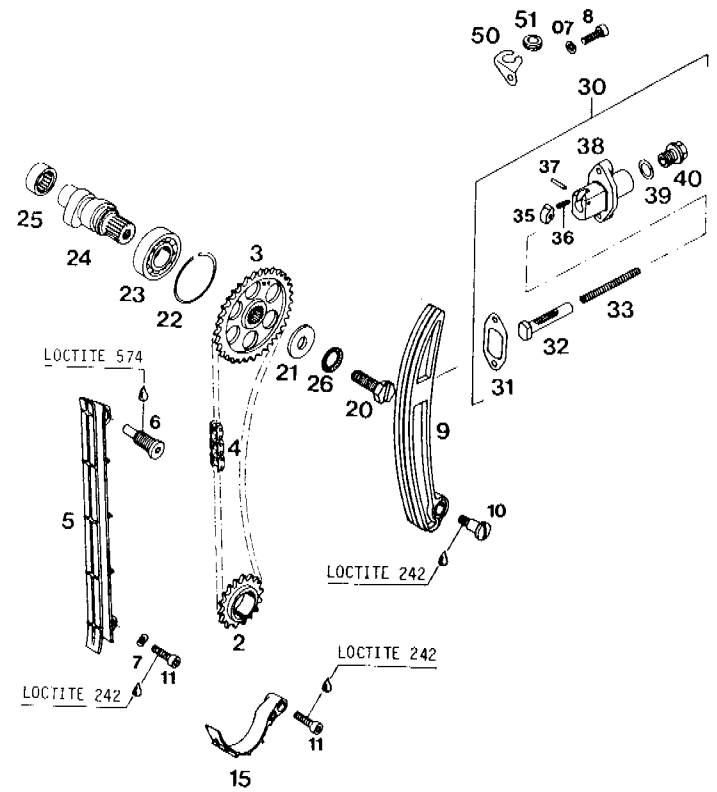
BILD FIG.	TEILENUMMER PART NUMBER	BEZEICHNUNG DESCRIPTION	STK. QTY.
1	580.38.001.000	ÖLPUMPENRAD 31-Z PUMP GEAR	1
2	0402 025980	NADELROLLE NROB 2,5 X 9,8 G2 NEEDLE	1
3	0912 060203	ISK-SCHRAUBE DIN912-M6X20 A H SCREW	3
5	580.38.007.100	ÖLPUMPE MIKUNI G-73 LC4'92 OIL PUMP CPL.	1
6	580.38.007.755	ANLAUFSCHIBE 8,1 X 15 X 0,5 THRUST WASHER	2
7	0799 060000	SICHERUNGSSCHIBE DIN6799-RS6 RETAINING CLIP	1
9	580.38.020.000	ÖLABLASSSCHRAUBE MIT MAGNET M12 OIL DRAIN PLUG	1
13	580.38.028.000	VENTILKOLBEN D=10MM VALVE PISTON	1
15	580.38.019.000	ÖLVERSCHLUSSSCHRAUBE M22X1,5 OIL DRAIN PLUG	1
16	580.38.017.000	DICHTRING 22 X 27 X 1 CU SEAL RING	1
17	0908 120153	VERSCHLUSSSCHRAUBE M12X1,5 PLUG	1
18	580.38.022.000	DICHTRING 12 X 18 X 1,5 CU SEAL RING	6
19	580.38.023.300	DRUCKFEDER L=25MM D=1MM SPRING	1
20	580.38.005.000	ÖLFILTER OIL FILTER ELEMENT	1
21	580.30.041.000	FILTERDECKELDICHUNG GASKET	1
22	580.30.008.600	FILTERDECKEL M10X1 '91 FILTERCOVER	1
23	0912 060163	ISK-SCHRAUBE DIN912-M6X16 A H SCREW	3
30*	580.38.234.200	ÖLLEITUNG FILTER/MIKROFILTER OIL LINE	1
		R10/R8 - 300MM	
31	580.38.334.600	ÖLLEITUNG FILTER/GEHÄUSE OIL LINE	1
		R10/R8 - 175MM	
32	580.38.134.600	ÖLLEITUNG MICROFILTER/KUPPL.DE OIL LINE	1
		R8/R8 - 190MM	
35	575.38.035.000	ÖLLEITUNG KURBELGEH./GETRIEBE OIL LINE	1
		R12/R12 - 465MM	
36	575.38.030.000	HOHLSCHRAUBE M12X1,5 DIN7643 HOLLOW SCREW	1
37*	580.38.030.100	HOHLSCHRAUBE M12 X 1,5 SW=10 HOLLOW SCREW	1
40	580.38.033.100	DOPPELHOHLSCHRAUBE M10X1 DUAL HOLLOW SCREW	1
43	580.38.030.000	HOHLSCHRAUBE M8X1 HOLLOW SCREW	4
45	580.38.032.010	DICHTRING 10 X 14 X 1 CU SEAL RING	3
46	580.38.032.000	DICHTRING 8,2 X 12 X 0,8 CU SEAL RING-CU	8



BILD FIG.	TEILENUMMER PART NUMBER	BEZEICHNUNG DESCRIPTION	STK. QTY.
50	580.38.041.000	MICROFILTERDECKEL FILTER COVER	1
51	0770 056020	O-RING 56 X 2 (VITON) O-RING	2
52	580.38.043.000	MICROFILTERGEHÄUSE FILTER CASE	1
53	580.38.044.000	MICROFILTERELEMENT FILTER ELEMENT	1
54	580.38.042.000	MICROFILTERDECKEL M8X1 FILTER COVER	1
55	0010 050163	TAPTITE SCHRAUBE M5X16 TAPETITE SCREW	4
56	575.38.090.000	HALTEBLECH FÜR MICROFILTER '93 BRACKET	1
57	575.38.091.000	STÜTZBLECH FÜR MICROFILTER '93 BRACKET	1
60*	0912 050163	ISK-SCHRAUBE DIN912-M5X16 A H SCREW	3
61	0021 050003	SCHEIBE DIN9021-A5,3 FLAT WASHER	3
62	544.31.032.050	DISTANZ BÜCHSE 6 X 8 X 8,5 SPACER BUSHING	3
63	310.08.060.000	KABELTÜLLE (INNENDURCHM. 8MM) RUBBER SLEEVE	3
64	546.03.048.200	MEHRBEREICHBLECHMUTTER M5 SHEET-METAL NUT	3

* = NEUTEILE / NEW PARTS

X = NACH BEDARF / AS REQUIRED

94-583.38.2 SCHMIERSYSTEM LC4 SX,EXC '94
LUBRICATION SYSTEM

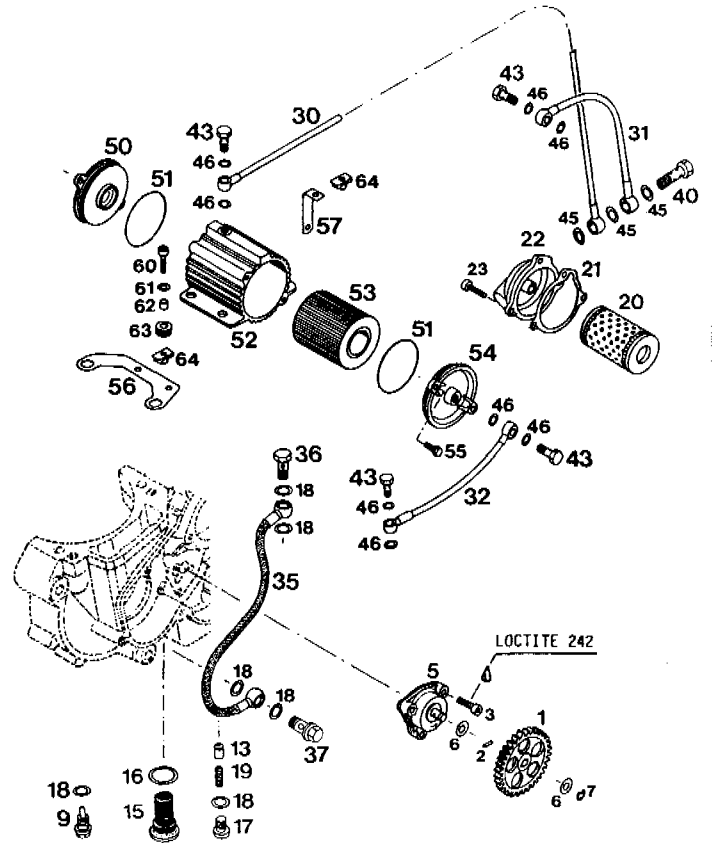
BILD FIG.	TEILENUMMER PART NUMBER	BEZEICHUNG DESCRIPTION	STK. QTY.
1	580.38.001.000	ÖLPUMPENRAD 31-Z PUMP GEAR	1
2	0402 025980	NADELROLLE NROB 2,5 X 9,8 G2 NEEDLE	1
3	0912 060203	ISK-SCHRAUBE DIN912-M6X20 A H SCREW	3
5	580.38.007.100	ÖLPUMPE MIKUNI G-73 LC4'92 OIL PUMP CPL.	1
6	580.38.007.755	ANLAUFSCHLEIBE 8,1 X 15 X 0,5 THRUST WASHER	2
7	0799 060000	SICHERUNGSSCHLEIBE DIN6799-RS6 RETAINING CLIP	1
9	580.38.020.000	ÖLABLASSSCHRAUBE MIT MAGNET M12 OIL DRAIN PLUG	1
13	580.38.028.000	VENTILKOLBEN D=10MM VALVE PISTON	1
15	580.38.019.000	ÖLVERSCHLUSSSCHRAUBE M22X1,5 OIL DRAIN PLUG	1
16	580.38.017.000	DICHTRING 22 X 27 X 1 CU SEAL RING	1
17	0908 120153	VERSCHLUSSSCHRAUBE M12X1,5 PLUG	1
18	580.38.022.000	DICHTRING 12 X 18 X 1,5 CU SEAL RING	6
19	580.38.023.300	DRUCKFEDER L=25MM D=1MM SPRING	1
20	580.38.005.000	ÖLFILTER OIL FILTER ELEMENT	1
21	580.30.041.000	FILTERDECKELDICHUNG GASKET	1
22	580.30.008.600	FILTERDECKEL M10X1 '91 FILTERCOVER	1
23	0912 060163	ISK-SCHRAUBE DIN912-M6X16 A H SCREW	3
30	580.38.234.200	ÖLLEITUNG FILTER/MIKROFILTER OIL LINE	1
31	580.38.334.600	ÖLLEITUNG FILTER/GEHÄUSE OIL LINE	1
32	580.38.134.600	ÖLLEITUNG MICROFILTER/KUPPL.DE OIL LINE	1
40	580.38.033.100	DOPPELHOHLSCHRAUBE M10X1 DUAL HOLLOW SCREW	1
43	580.38.030.000	HOHLSCHRAUBE M8X1 HOLLOW SCREW	4
45	580.38.032.010	DICHTRING 10 X 14 X 1 CU SEAL RING	3
46	580.38.032.000	DICHTRING 8,2 X 12 X 0,8 CU SEAL RING-CU	8
50	580.38.041.000	MICROFILTERDECKEL FILTER COVER	1
51	0770 056020	O-RING 56 X 2 (VITON) O-RING	2
52	580.38.043.000	MICROFILTERGEHÄUSE FILTER CASE	1



BILD FIG.	TEILENUMMER PART NUMBER	BEZEICHUNG DESCRIPTION	STK. QTY.
53	580.38.044.000	MICROFILTERELEMENT FILTER ELEMENT	1
54	580.38.042.000	MICROFILTERDECKEL M8X1 FILTER COVER	1
55	0010 050163	TAPTITE SCHRAUBE M5X16 TAPITITE SCREW	4
56	575.38.090.000	HALTEBLECH FÜR MICROFILTER BRACKET	93
57	575.38.091.000	STÜTZBLECH FÜR MICROFILTER '93 BRACKET	1
60	0912 050163	ISK-SCHRAUBE DIN912-M5X16 A H SCREW	3
61	0021 050003	SCHLEIBE DIN9021-A5,3 FLAT WASHER	3
62	544.31.032.050	DISTANZ BÜCHSE 6 X 8 X 8,5 SPACER BUSHING	3
63	310.08.060.000	KABELTÜLLE (INNENDURCHM. 8MM) RUBBER SLEEVE	3
64	546.03.048.200	MEHRBEREICHBLECHMUTTER M5 SHEET-METAL NUT	3
70	575.38.030.000	HOHLSCHRAUBE M12X1,5 DIN7643 HOLLOW SCREW	2
72*	575.38.135.000	ÖLLEITUNG KURBELGEH./GETRIEBE OIL LINE R12/R12 - 70MM	1

* = NEUTEILE / NEW PARTS

X = NACH BEDARF / AS REQUIRED

94-583.38.3

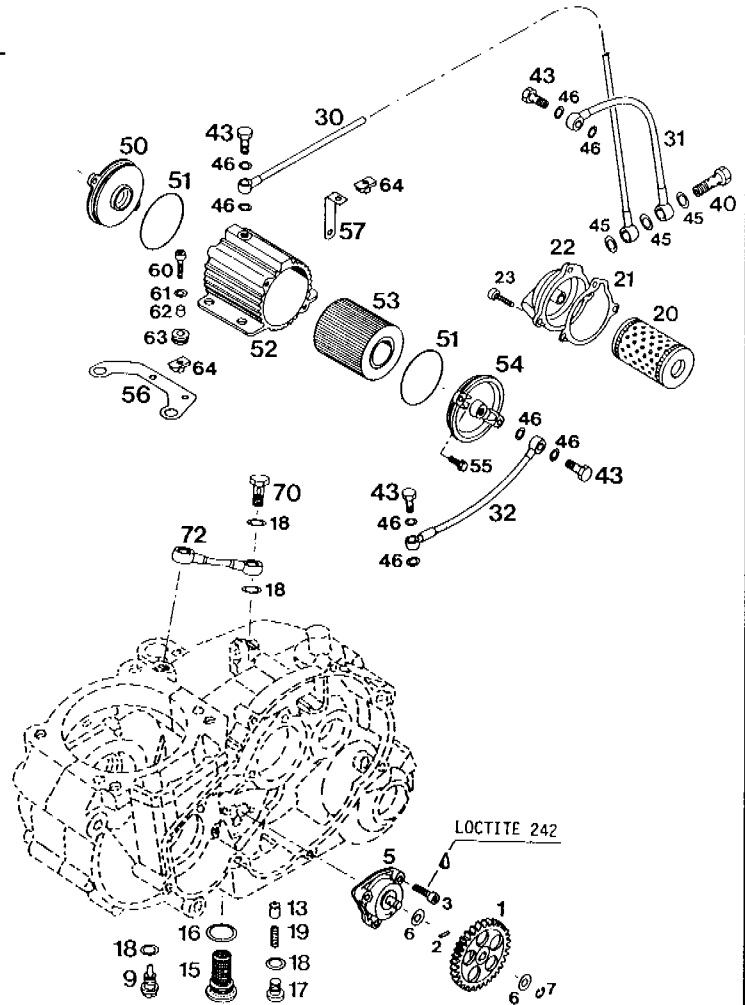
SCHMIERSYSTEM LC4 EGS,RXC,EXC
LUBRICATION SYSTEM

BILD FIG.	TEILENUMMER PART NUMBER	BEZEICHUNG DESCRIPTION	STK. QTY.
1	580.38.001.000	ÖLPUMPENRAD 31-Z PUMP GEAR	1
2	0402 025980	NADELROLLE NROB 2,5 X 9,8 G2 NEEDLE	1
3	0912 060203	ISK-SCHRAUBE DIN912-M6X20 A H SCREW	3
5	580.38.007.100	ÖLPUMPE MIKUNI G-73 LC4'92 OIL PUMP CPL.	1
6	580.38.007.755	ANLAUFSCHLEIBE 8,1 X 15 X 0,5 THRUST WASHER	2
7	0799 060000	SICHERUNGSSCHLEIBE DIN6799-RS6 RETAINING CLIP	1
9	580.38.020.000	ÖLABLASSSCHRAUBE MIT MAGNET M12 OIL DRAIN PLUG	1
12	543.13.025.000	HOHLSCHRAUBE M10X1X19 CONNECTING SCREW	2
13	580.38.028.000	VENTILKOLBEN D=10MM VALVE PISTON	1
15	580.38.019.000	ÖLVERSCHLUSSSCHRAUBE M22X1,5 OIL DRAIN PLUG	1
16	580.38.017.000	DICHTRING 22 X 27 X 1 CU SEAL RING	1
17	0908 120153	VERSCHLUSSSCHRAUBE M12X1,5 PLUG	1
18	580.38.022.000	DICHTRING 12 X 18 X 1,5 CU SEAL RING	6
19	580.38.023.300	DRUCKFEDER L=25MM D=1MM SPRING	1
20	580.38.005.000	ÖLFILTER OIL FILTER ELEMENT	1
21	580.30.041.000	FILTERDECKELDICHUNG GASKET	1
22	580.30.008.600	FILTERDECKEL M10X1 '91 FILTERCOVER	1
23	0912 060163	ISK-SCHRAUBE DIN912-M6X16 A H SCREW	3
30	580.38.234.700	ÖLLEITUNG FILTER/RAHMEN OIL LINE R10/R10 - 865MM	1
31	580.38.334.600	ÖLLEITUNG FILTER/GEHÄUSE OIL LINE R10/R8 - 175MM	1
32	580.38.134.600	ÖLLEITUNG MICROFILTER/KUPPL.DE OIL LINE R8/R8 - 190MM	1
33	580.38.434.000	ÖLLEITUNG RAHMEN/MICROFILTER OIL LINE R10/R8 - 593MM	1
40	580.38.033.100	DOPPELHOHLSCHRAUBE M10X1 DUAL HOLLOW SCREW	1
43	580.38.030.000	HOHLSCHRAUBE M8X1 HOLLOW SCREW	4
45	580.38.032.010	DICHTRING 10 X 14 X 1 CU SEAL RING	7
46	580.38.032.000	DICHTRING 8,2 X 12 X 0,8 CU SEAL RING-CU	8
50	580.38.041.000	MICROFILTERDECKEL FILTER COVER	1



BILD FIG.	TEILENUMMER PART NUMBER	BEZEICHUNG DESCRIPTION	STK. QTY.
51	0770 056020	O-RING 56 X 2 (VITON) O-RING	2
52	580.38.043.000	MICROFILTERGEHÄUSE FILTER CASE	1
53	580.38.044.000	MICROFILTERELEMENT FILTER ELEMENT	1
54	580.38.042.000	MICROFILTERDECKEL M8X1 FILTER COVER	1
55	0010 050163	TAPTITE SCHRAUBE M5X16 TAPTITE SCREW	4
56	575.38.090.000	HALTEBLECH FÜR MICROFILTER '93 BRACKET	1
57	575.38.091.000	STÜTZBLECH FÜR MICROFILTER '93 BRACKET	1
60*	0912 050163	ISK-SCHRAUBE DIN912-M5X16 A H SCREW	3
61	0021 050003	SCHLEIBE DIN9021-A5,3 FLAT WASHER	3
62	544.31.032.050	DISTANZ BÜCHSE 6 X 8 X 8,5 SPACER BUSHING	3
63	310.08.060.000	KABELTÜLE (INNENDURCHM. 8MM) RUBBER SLEEVE	3
64	546.03.048.200	MEHRBEREICHBLECHMUTTER M5 SHEET-METAL NUT	3
70	575.38.030.000	HOHLSCHRAUBE M12X1,5 DIN7643 HOLLOW SCREW	2
72*	575.38.135.000	ÖLLEITUNG KURBELGEH./GETRIEBE OIL LINE R12/R12 - 70MM	1

* = NEUTEILE / NEW PARTS

X = NACH BEDARF / AS REQUIRED

93-580.38.1 MOTORENTLÜFTUNG 350-612 LC4'93
BREATHER SYSTEM

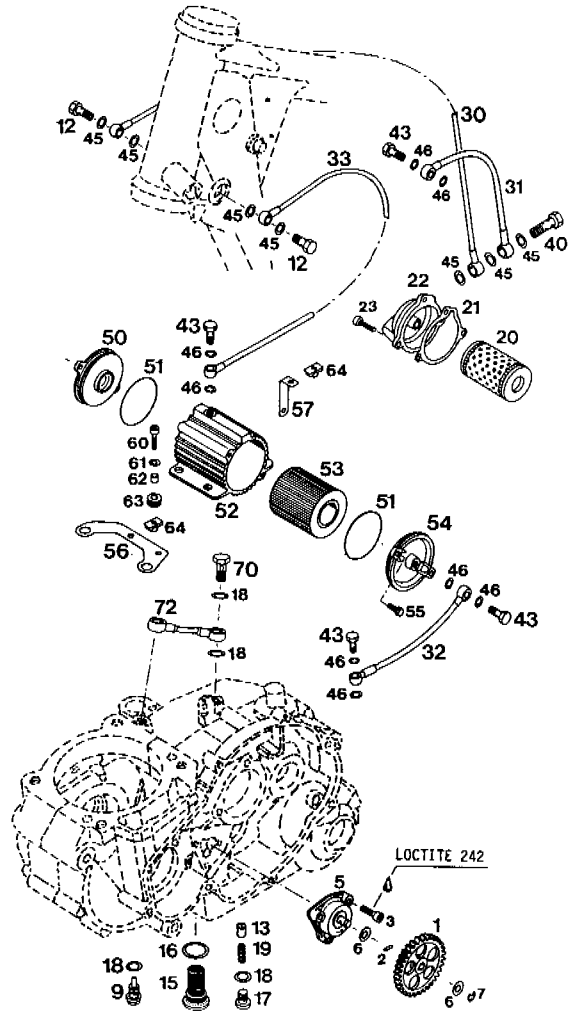
BILD FIG.	TEILENUMMER PART NUMBER	BEZEICHNUNG DESCRIPTION	STK. QTY.
1	580.35.025.800	ENTLÜFTUNGSSCHLAUCH BREATHER TUBE	1
2	100.01.020.000	SCHLAUCHBINDER A2 CLAMP	4
3	575.30.090.000	ENTLÜFTUNGSSCHLAUCH BREATHER TUBE '93	1

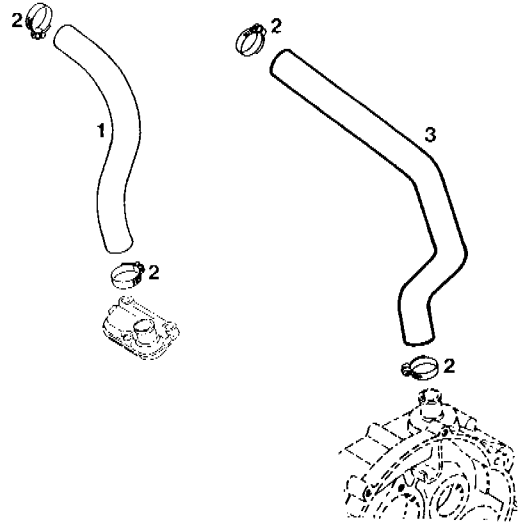

94-575.31.0 VERGASER DELL'ORTO PHBE 36 HD
CARBURETTOR

BILD FIG.	TEILENUMMER PART NUMBER	BEZEICHNUNG DESCRIPTION	STK. QTY.
1-49	575.31.101.044	VERGASER PHBE 36 SD (6835) CARBURETTOR	1
1-49	575.31.101.244	VERGASER PHBE 36HD (6835/3) CARBURETTOR	1
1	575.31.135.040	GASSCHIEBER 40 THROTTLE VALVE	1
2	490.31.134.051	DÜSENNADEL K 51 JET NEEDLE	1
3	580.31.121.266	NAELEDÜSE DR 266 NEEDLE JET	X
3*	580.31.121.268	NAELEDÜSE DR 268 NEEDLE JET	1
3	580.31.121.270	NAELEDÜSE DR 270 NEEDLE JET	1
4	570.31.523.135	HAUPTDÜSE 135 MAIN JET	1
4	570.31.523.180	HAUPTDÜSE 180 MAIN JET	1
5	151.31.123.038	LEERLAUFDÜSE 38 IDLE JET	X
5*	151.31.123.045	LEERLAUFDÜSE 45 PILOT JET 45	1
5	151.31.123.052	LEERLAUFDÜSE 52 IDLE JET	1
6	570.31.551.045	STARTDÜSE 45 STARTING JET	1
7	572.31.120.300	NADELVENTIL 300 NEEDLE VALVE	1
8	570.31.509.000	SCHWIMMER 8,5 GRAMM FLOAT	1
10	520.31.138.000	GUMMITÖLLE RUBBER PLUG	2
11	570.31.524.000	SK-SCHRAUBE M5X16 H H SCREW	2
12	570.31.525.100	STELLSCHRAUBE M6X0,75 ADJ. SCREW	1
13	501.31.127.000	VERGASERDECKEL MIXT. CHAMBER COVER	1
14	570.31.130.000	SCHIEBERFEDER 1,25 X 180 SPRING	1

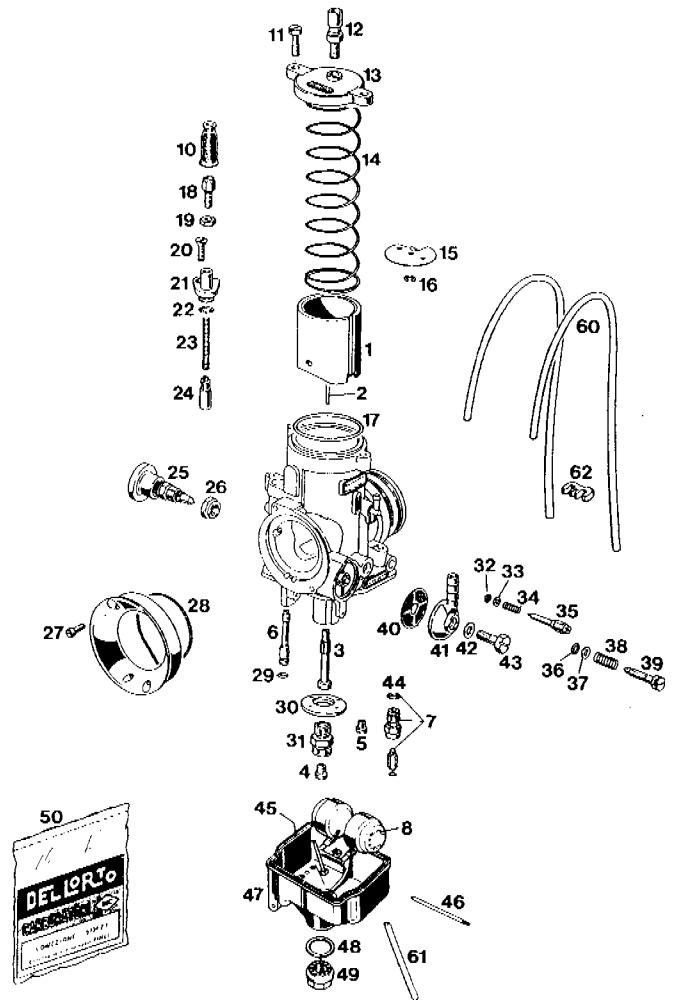

94-575.31.0 VERGASER DELL'ORTO PHBE 36 HD
CARBURETTOR

BILD FIG.	TEILENUMMER PART NUMBER	BEZEICHUNG DESCRIPTION	STK. QTY.
15	544.31.532.000	HALTESCHEIBE NEEDLE CLIP	1
16	0799 025055	SICHERUNGSSCHEIBE RS2,5X5,5 CLIP	1
18	570.31.525.000	STELLSCHRAUBE M6X0,75 ADJ. SCREW	1
19	520.31.126.000	SK-MUTTER M6X0,75 NUT	1
20	0963 045143	SENKSCHEIBE M4,5X14 COUNTERSUNK SCREW	1
21	570.31.555.000	DECKEL FÜR STARTGEHÄUSE COVER	1
23	580.31.153.000	FEDER SPRING	1
24	570.31.549.000	STARTKOLBEN STARTING DEVICE	1
25	580.31.180.000	WARMSTARTKNOPF PUSHBUTTON	1
26	580.31.181.000	SK-MUTTER M9X0,75 NUT	1
27	0912 040123	ISK-SCHRAUBE DIN912-M4X12 ALLEN HEAD SCREW	2
30	501.31.174.000	PRALLBLECH COVER	1
31	570.31.522.000	DÜSENSTOCK MAIN JET HOLDER	1
33	570.31.572.000	SCHEIBE 3,3 X 5,8 X 0,5 WASHER	1
34	570.31.515.000	FEDER SPRING	1
35	570.31.517.000	GEMISCHREG.SCHRAUBE M7X0,75 MIXTURE REG. SCREW	1
37	570.31.573.000	SCHEIBE 5,1 X 8 X 0,8 WASHER	1
38	520.31.116.000	FEDER SPRING	1
39	570.31.519.000	STELLSCHRAUBE M5 ADJ. SCREW	1
40	151.31.112.000	KRAFTSTOFFFILTER FUEL FILTER	1
41	570.31.513.000	SCHLAUCHANSCHLUSS FUEL INLET BANJO	1
43	0933 060163	SK-SCHRAUBE DIN933-M6X16 H H SCREW	1
46	570.31.508.000	STIFT 2 X 47 FLOAT PIN	1
47	570.31.511.100	SCHWIMMERGEHÄUSE M ÜBERLAUF. FLOAT CHAMBER	1
49	570.31.514.000	VERSCHLUSSSCHRAUBE M12X1 PLUG	1

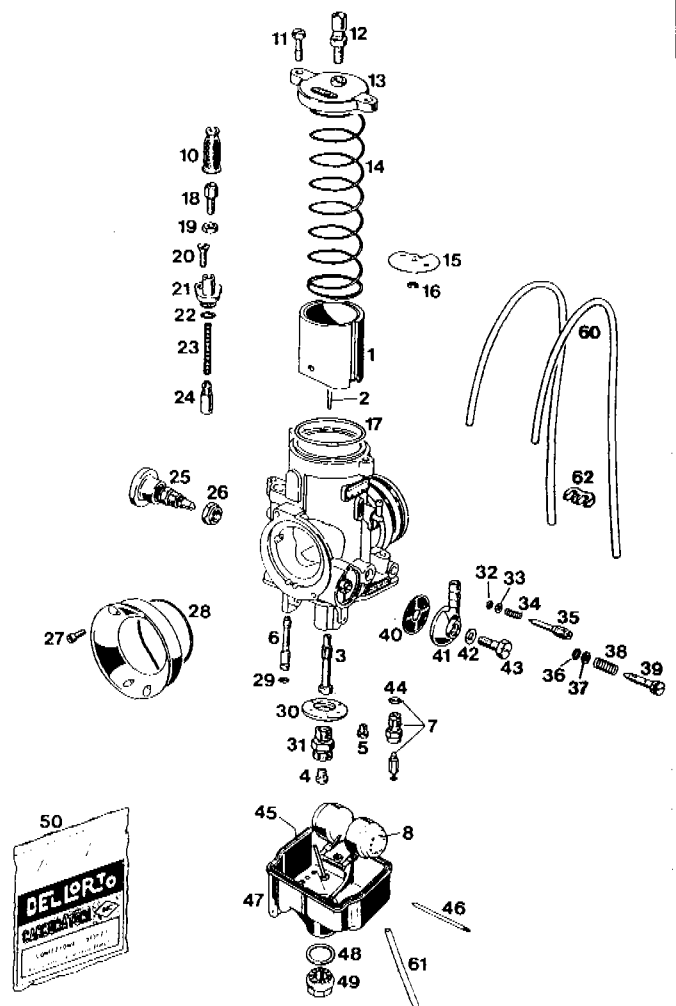

50	575.31.199.000	DICHTUNGSSATZ PHBE 36 HD GASKET SET	1
60	501.31.137.000	ENTLÜFTUNGSSCHLAUCH 3X5X190 BREATHER TUBE	2
61	520.31.137.001	PVC-SCHLAUCH 3X6 (ÜBERLAUF) TUBE 3X6	0,45
62	830.13.096.000	KABELKLAMMER, 3-FACH, SCHWARZ CLAMP	1

94-583.31.0

VERGASER DELL'ORTO PHM 38/40SD
CARBURETTOR

BILD FIG.	TEILENUMMER PART NUMBER	BEZEICHUNG DESCRIPTION	STK. QTY.
1-52	580.31.601.644	VERGASER PHM 38 SD (4920) CARBURETTOR	1
1-52	580.31.601.844	45 / 38 / 135 / DR266 / K51 II VERGASER PHM 38 SD (4894/6) CARBURETTOR	1
1-52	580.31.601.944	45 / 45 / 190 / DR270 / K51 II VERGASER PHM 38 SD (4920/1CH) CARBURETTOR	1
1-52	580.31.701.044	45 / 38 / 135 / DR266 / K51 II VERGASER PHM 38 SD (4920/3) CARBURETTOR	1
1-52	580.31.701.144	45 / 45 / 170 / DR268/K51 III VERGASER PHM 38 SD (4920/4) CARBURETTOR	1
1-52	580.31.901.544	45 / 45 / 140 / DR268/K51 III VERGASER PHM 40 SD (4922) CARBURETTOR	1
1-52	580.31.901.244	45 / 45 / 195 / DR272 / K51 II VERGASER PHM 40 SD (4922/3) CARBURETTOR	1
1-52	580.31.901.444	45 / 45 / 135 / DR268/K51 III VERGASER PHM 40 SD (4922/3 CH) CARBURETTOR	1
1-52	580.31.901.144	45 / 45 / 135 / DR268/K51 III VERGASER PHM 40 SD (4922/2) CARBURETTOR	1
1	580.31.135.040	GASSCHIEBER NR.40 THROTTLE VALVE	1
2	490.31.134.051	DÜSENNADEL K 51 JET NEEDLE	1
3	580.31.121.272	NAELEDÜSE DR 272 NEEDLE JET	1
3	580.31.121.270	NAELEDÜSE DR 270 NEEDLE JET	X
3*	580.31.121.268	NAELEDÜSE DR 268 NEEDLE JET	1
3	580.31.121.266	NAELEDÜSE DR 266 NEEDLE JET	1
4	570.31.523.200	HAUPTDÜSE 200 MAIN JET	X
4*	570.31.523.195	HAUPTDÜSE 195 MAIN JET	1
4	570.31.523.190	HAUPTDÜSE 190 MAIN JET	X
4*	570.31.523.170	HAUPTDÜSE 170 MAIN JET	1
4	570.31.523.160	HAUPTDÜSE 160 MAIN JET	X
4*	570.31.523.140	HAUPTDÜSE 140 MAIN JET	1
4	570.31.523.135	HAUPTDÜSE 135 MAIN JET	1
5	151.31.123.045	LEERLAUFDÜSE 45 PILOT JET 45	1
5	151.31.123.038	LEERLAUFDÜSE 38 IDLE JET	1

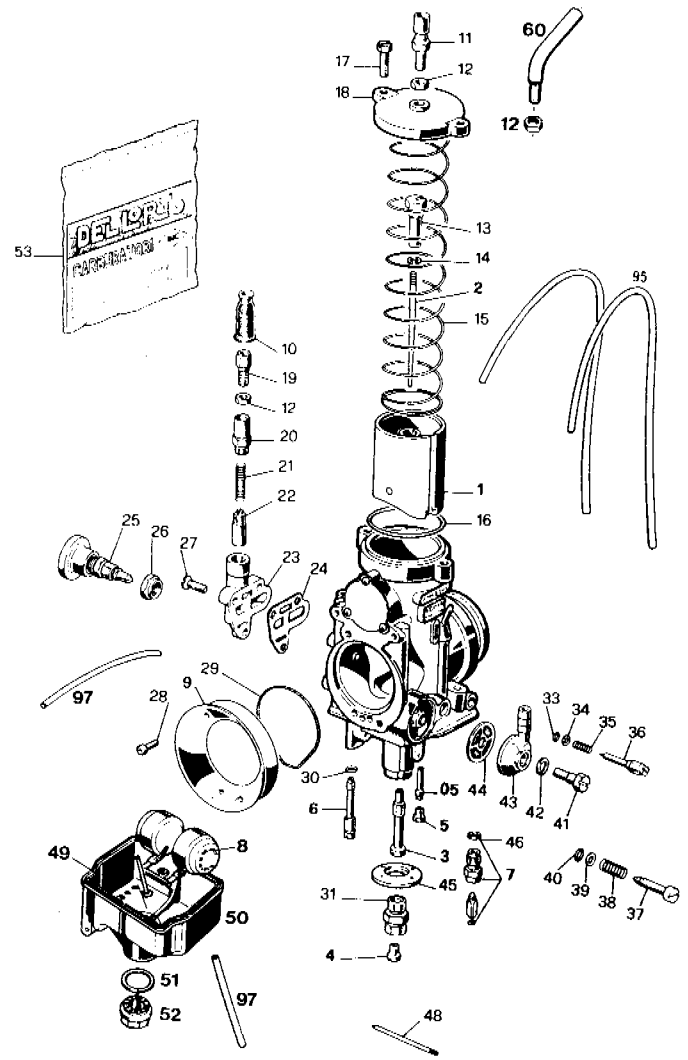

* = NEUTEILE / NEW PARTS

X = NACH BEDARF / AS REQUIRED

94-583.31.0 VERGASER DELL'ORTO PHM 38/40SD
CARBURETTOR

BILD FIG.	TEILENUMMER PART NUMBER	BEZEICHNUNG DESCRIPTION	STK. QTY.
05	490.31.122.000	LEERLAUFMISCHROHR NR.1 CD IDLE EMULSION TUBE	1
6	580.31.151.045	STARTDÜSE 45 STARTING JET	1
7	572.31.120.300	NADELVENTIL 300 NEEDLE VALVE	1
8	570.31.509.000	SCHWIMMER 8,5 GRAMM FLOAT	X
8*	583.31.509.000	SCHWIMMER 6,5 GRAMM FLOAT	1
9	580.31.140.038	ANSAUGTRICHTER 38 CONNECT.AIR INTAKE	400 LC4 1
9*	580.31.140.040	ANSAUGTRICHTER 40 CONNECT.AIR INTAKE	620 LC4 1
10	520.31.138.000	GUMMITÜLLE RUBBER PLUG	1
11	570.31.525.100	STELLSCHRAUBE M6X0,75 ADJ. SCREW	1
12	520.31.126.000	SK-MUTTER M6X0,75 NUT	3
13	490.31.131.000	NIPPEL NIPPLE	1
14	0799 025055	SICHERUNGSSCHEIBE RS2,5X5,5 CLIP	1
15	544.31.530.000	SCHIEBERFEDER 1,25 X 190 SPRING	1
17	570.31.524.000	SK-SCHRAUBE M5X16 H H SCREW	2
18	580.31.127.000	VERGASERDECKEL COVER PLATE	1
19	570.31.525.000	STELLSCHRAUBE M6X0,75 ADJ. SCREW	1
20	572.31.155.000	VERSCHRAUBUNG PLUG	1
21	580.31.153.000	FEDER SPRING	1
22	570.31.549.000	STARTKOLBEN STARTING DEVICE	1
23	572.31.150.100	KALTSTARTVERGASERGEHÄUSE 4-T. START.DEVICE BODY	1
25	580.31.180.000	WARMSTARTKNOPF PUSHBUTTON	1
26	580.31.181.000	SK-MUTTER M9X0,75 NUT	1
27	0964 040143	LINSENSCHRAUBE DIN964-M4X14 FLAT HEAD SCREW	3
28	0912 040123	ISK-SCHRAUBE DIN912-M4X12 ALLEN HEAD SCREW	2
31	570.31.522.000	DÜSENSTOCK MAIN JET HOLDER	1
34	570.31.572.000	SCHEIBE 3,3 X 5,8 X 0,5 WASHER	1
35	570.31.515.000	FEDER SPRING	1
36	570.31.517.000	GEMISCHREG.SCHRAUBE M7X0,75 MIXTURE REG.SCREW	1
37	570.31.519.000	STELLSCHRAUBE M5 ADJ. SCREW	1



BILD FIG.	TEILENUMMER PART NUMBER	BEZEICHNUNG DESCRIPTION	STK. QTY.
38	520.31.116.000	FEDER SPRING	1
39	570.31.573.000	SCHEIBE 5,1 X 8 X 0,8 WASHER	1
41	0933 060163	SK-SCHRAUBE DIN933-M6X16 H H SCREW	1
43	570.31.513.000	SCHLAUCHANSCHLUSS FUEL INLET BANJO	1
44	151.31.112.000	KRAFTSTOFFFILTER FUEL FILTER	1
45	501.31.174.000	PRALLBLECH COVER	1
48	570.31.508.000	STIFT 2 X 47 FLOAT PIN	1
50	570.31.511.100	SCHWIMMERGEHÄUSE M ÜBERLAUFR. FLOAT CHAMBER	1
52	570.31.514.000	VERSCHLUSSSCHRAUBE M12X1 PLUG	1
53	580.31.199.000	DICHT.SATZ PHM38SD / PHM40SD GASKET SET	1
60	580.31.160.000	ROHRBOGEN TUBE WITH THREAD	4T'92 1
95	310.07.007.001	SCHLAUCH 5 X 8 PER METER BREATHER HOSE 5X8	0,5
97	520.31.137.001	PVC-SCHLAUCH 3X6 (ÜBERLAUF) TUBE 3X6	0,6

* = NEUTEILE / NEW PARTS X = NACH BEDARF / AS REQUIRED

93-580.31.5 ZÜNDANLAGE 350-620 LC4'93
IGNITION SYSTEM

BILD FIG.	TEILENUMMER PART NUMBER	BEZEICHNUNG DESCRIPTION	STK. QTY.
1	580.31.002.000	ZÜNDANLAGE SEM K10/60 EG LINKS IGNITION CPL.	1
2	580.31.002.050	STATOR FÜR ZÜNDANLAGE LC4 STATOR	1
3	580.31.002.051	ROTOR FÜR ZÜNDANLAGE LC4 FLYWHEEL	1
5	0084 050303	ZYL.SCHRAUBE DIN84A-M5X30 FIL.HEAD SCREW	3
6	0125 050003	SCHEIBE DIN125-A5,3 FLAT WASHER	3
7	0500 050083	TAPETITE SCHRAUBE M5X8 TAPETITE SCREW	1
8	500.31.003.000	HALTEPLÄTTCHEN RETAINING PLATE	1
9	0137 050003	FEDERSCHEIBE DIN137-B5 SPRING WASHER	1
10	580.30.002.200	ZÜNDUNGSDECKEL SCHWARZ IGNITION COVER	1
11	0770 020490	O-RING 2-49 (126,72 X 1,78) O-RING	1
12	580.31.004.000	GUMMIDURCHFÜHRUNG RUBBER SLEEVE	1
13	580.30.002.050	VERSCHLUSSSCHRAUBE M18X1,5 SCREW PLUG	1
14	0912 060253	ISK-SCHRAUBE DIN912-M6X25 A H SCREW	4
15	0125 060003	SCHEIBE DIN125-A6,4 FLAT WASHER	4
20	580.31.006.000	ZÜNDSPULE TM 14-05 IGNITION COIL	1
21	0931 060503	SK-SCHRAUBE DIN931-M6X50 H H SCREW	2
22	0125 060003	SCHEIBE DIN125-A6,4 FLAT WASHER	2
23	0985 060003	SS-MUTTER DIN985-M6 S L NUT	2
30	580.31.093.005	ZÜNDKERZE NGK D8 EA SPARKING PLUG	1
31	580.31.010.000	ZÜNDKERZENSTECKER SD 05 F MX SPARK PLUG PROTECT	1
32	580.31.410.044	ZÜNDKERZENSTECKER 10 30 00 KPL SPARK PLUG PROTECT	1

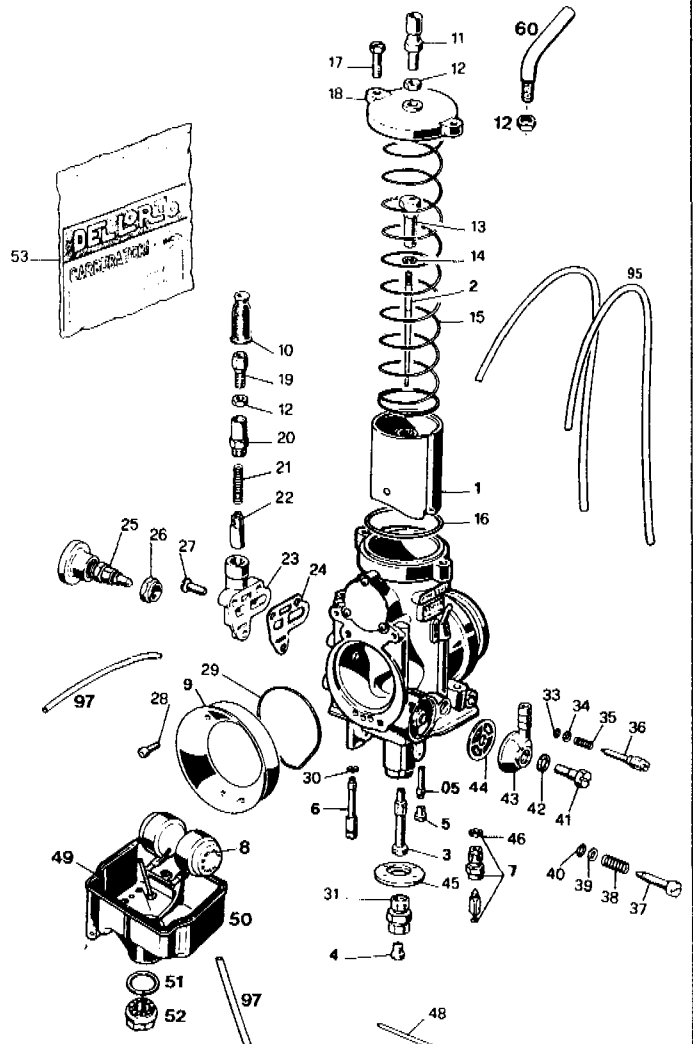
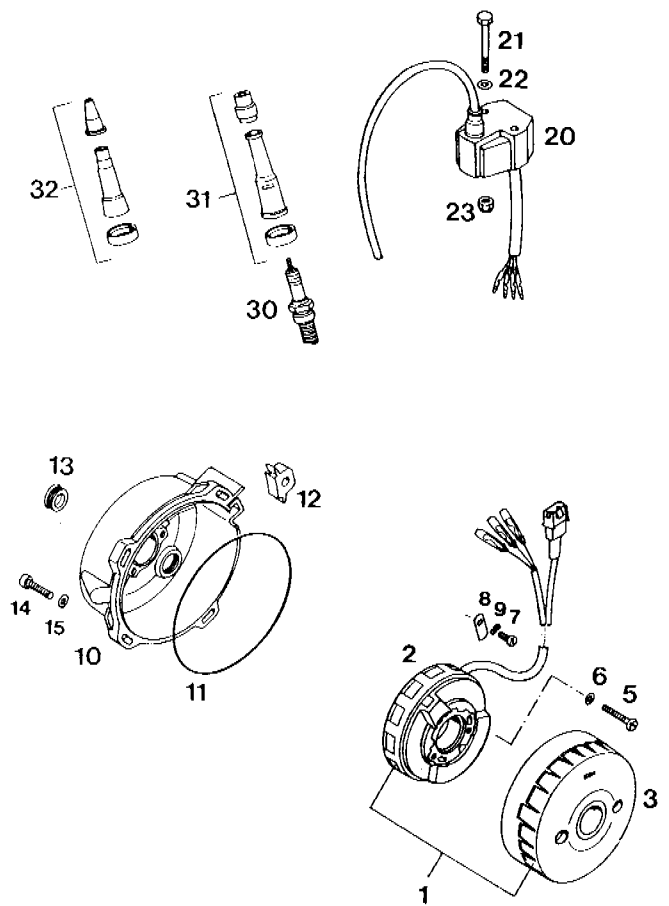

94-583.32.1 KUPPLUNG 350-620 LC4'94
CLUTCH

BILD FIG.	TEILENUMMER PART NUMBER	BEZEICHNUNG DESCRIPTION	STK. QTY.
1	580.32.101.144	KUPPLUNGSKORB 81/22-Z M.PR.30Z OUTER CLUTCH HUB	1
2	580.32.001.000	KUPPLUNGSKORB LOSE OUTER CL.HUB LOOSE	1
3	580.32.007.000	NIET DIN 7338 8 X 11,2 RIVET	6
4*	503.32.070.000	INNENRING MIT BUND INNER BUSHING	1
5	575.32.013.000	STÜTZSCH. GEHÄRTET 22,2X35X3 THRUST WASHER	1
6	565.32.095.000	NADELKÄFIG K 26 X 30 X 22 NEEDLE CAGE	1
7	580.32.112.000	STAHLLAMELLE 4 TAKT 1,4 MM CLUTCH DISC	2
8	580.32.012.500	STAHLLAMELLE 2 MM STEEL DISC	5
9	580.32.011.100	BELAGLAMELLE 3,0 MM ORGANIC DISC	6
10	565.32.002.500	MITNEHMER "5" INNER CLUTCH HUB	LC4'90 1
10*	565.32.002.100	MITNEHMER "1" INNER CLUTCH HUB	'94 1
11	565.32.018.000	440/500/LC4-SINTERKUPPLUNG SICHERUNGSBLECH FLAT WASHER	1
12	0936 181505	SK-MUTTER DIN936-M18X1,5 - 8.8 HEX NUT	1
13	565.32.003.100	DRUCKKAPPE PRESSURE PLATE	1
14	543.32.001.000	KUPPL.DRUCKFEDER 2,5 X 38 (7W) CLUTCH SPRING	6
14	544.32.001.100	ORGANISCHE KUPPLUNG ORGANIC CLUTCH	6
15	502.32.050.000	DRUCKFEDER 2,7 X 38 CLUTCH SPRING	6
16*	0912 060203	ISK-SCHRAUBE DIN912-M6X20 A H SCREW	6
17	580.32.014.000	AUSRÜCKHEBEL 4-T. DISENGAGING LEVER	1
18	0912 060203	ISK-SCHRAUBE DIN912-M6X20 A H SCREW	1
19	545.32.013.000	HALTEBLECH F.AUSRÜCKUNG RETAINING PLATE	1
20	0991 060122	SENKSCHEIBE DIN7991-M6X12 ALLEN FLATHEAD SCR	2
21	545.32.093.000	NUTRING N 12 X 20 X 5,5 SEAL RING	1
22	0471 120010	SEEGERRING DIN471-12X1 CIRCLIP	1
23	503.32.095.000	NADELHÜLSE HK 1212 NEEDLE CAGE	2
24	575.32.015.000	AUSRÜCKWELLE 12 X 66 DISENGAGING SHAFT	'93 1



BILD FIG.	TEILENUMMER PART NUMBER	BEZEICHNUNG DESCRIPTION	STK. QTY.
25	575.32.017.000	DRUCKSTANGE 206 MM PUSH ROD	'93 1
26	565.32.032.300	AUFLAGEBOLZEN PRESSURE BOLT	1
27	543.32.030.000	AXIAL-NADELKRANZ AXK 1024 KPL. AXIAL NEEDLE BEARG	1
28	0471 100010	SEEGERRING DIN471-10X1 CIRCLIP	1
30	0094 150223	SPLINT DIN94-1,5X22 PIN	1
40	580.32.012.500	STAHLLAMELLE 2 MM STEEL DISC	2
41*	580.32.012.000	STAHLLAMELLE 1 MM CLUTCH DISC	8
42*	565.32.011.300	SINTERLAMELLE 2 MM CLUTCH DISC	9

* = NEUTEILE / NEW PARTS

X = NACH BEDARF / AS REQUIRED

94-583.33.1 KICKSTARTER 350-620 LC4'94
KICKSTARTER

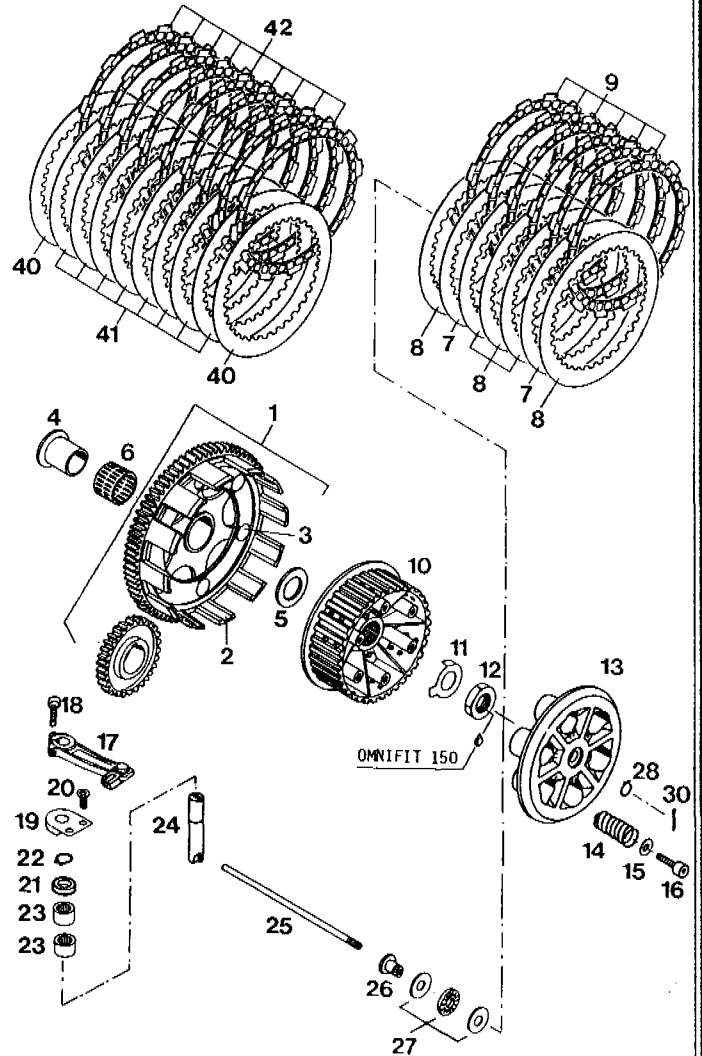
BILD FIG.	TEILENUMMER PART NUMBER	BEZEICHUNG DESCRIPTION	STK. QTY.
1A*	580.33.026.200 ■	MITNEHMERNABE DRIVING HUB	'94 1
1B	580.33.026.100 ■	MITNEHMERNABE DRIVING HUB	1
2	580.33.020.000	STARTERFEDER KICKSTARTER SPRING	1
3	520.33.096.000	SPRENGRING 25 X 1,6 CIRCLIP	1
03	520.33.090.100	SPRENGRING SW25 CIRCLIP	1
4	580.33.037.000	FEDERFUHRUNG SPRING BUSHING	1
5	580.33.028.000	SPERRADFEDER 1,2 MM SPRING	1
6	580.33.023.100	SPERRRAD 18-Z KICKST. RATCHET	1
7	580.38.022.000	DICHTRING 12 X 18 X 1,5 CU SEAL RING	1
8	580.33.033.000	ANSCHLAGSCHRAUBE M12X1,5 ADJUSTING BOLT	1
9	546.32.090.000	DICHTRING G 12 X 16 X 3 SEAL RING	1
10A*	580.33.021.300 ■	KICKSTARTERWELLE KICKSTARTER SHAFT	'94 1
10B	580.33.021.200 ■	KICKSTARTERWELLE KICKSTARTER SHAFT	1
11	580.33.031.000	ANLAUFSCHIBE 22 X 30 X 1,5 WASHER	1
12	565.33.098.000	NADELKÄFIG K 22 X 26 X 13 NEEDLE CAGE	1
13	580.33.022.600	STARTERRAD 35 Z KICKSTARTER GEAR	1
14	580.33.024.000	STARTERZWISCHENRAD 37-Z INTERMEDIATE GEAR	1
15	565.32.012.000	ANLAUFSCHIBE 22,2 X 35 X 2 THRUST WASHER	1
16	580.33.090.000	NADELLAGER RNA 4903 NEEDLE BEARING	1
17	0760 223270	WELLENDICHTRING 22X32X7 BSL SEAL RING	1
20*	583.33.036.044	KICKSTARTER KPL. ALU LC4'94 KICKSTARTER CPL.	1
21*	0912 080253	ISK-SCHRAUBE DIN912-M8X25 A H SCREW	1
22*	360.03.014.000	SCHNORR-SICHERUNGSSCHEIBE 8MM LOCK WASHER	1

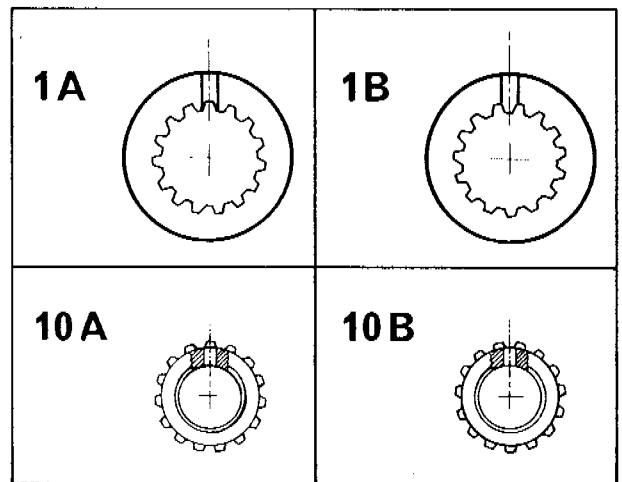
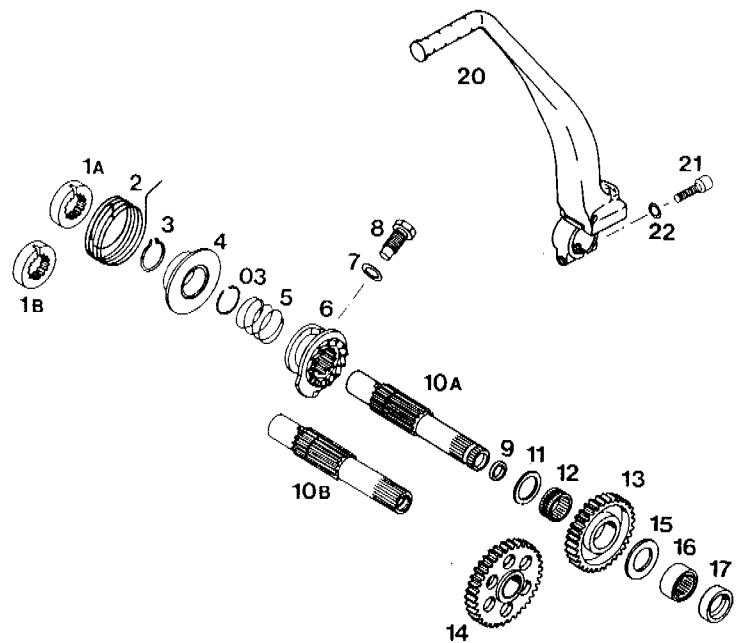

94-583.33.2 GETRIEBE I 350-620 LC4'94
TRANSMISSION I

BILD FIG.	TEILENUMMER PART NUMBER	BEZEICHNUNG DESCRIPTION	STK. QTY.
1	575.33.002.000	ANTRIEBSWELLE 15Z MAIN SHAFT	'93 1
2	565.33.110.400	FESTRAD 2.G 16 Z (2M4) 2ND G. MAINSHAFT	1
2*	565.33.010.300	FESTRAD 2.G 15 Z (2G3) 2ND G. MAINSHAFT 350-620 EGS/RXC, 400 EXC USA	1
3	565.33.004.300	LOSRAD 3.G 18 Z (3M3) 3RD GEAR COUNTERS.	1
4	565.33.006.300	SCHIEBERAD 4.G 20 Z (4M3) 4TH GEAR MAINSHAFT	1
5	565.33.008.300	LOSRAD 5.G 27 Z (5M3) 5TH GEAR COUNTERS.	1
6	565.33.016.300	ANLAUFSCHEIBE 22,7 X 32 X 1,5 THRUST WASHER	2
8	565.33.015.000	ANLAUFSCHEIBE 20,2 X 35 X 1 THRUST WASHER	1
9	565.33.099.000	NADELKÄFIG K22X26X13 GETEILT NEEDLE CAGE	2
10	520.33.096.000	SPRENGRING 25 X 1,6 CIRCLIP	2
11	0625 201029	RILLENKUGELLAGER 6304/22/C4QE6 BALL BEARING	1
12	565.33.093.000	NADELLAGER RNA 4902 KSE NEEDLE BEARING	1

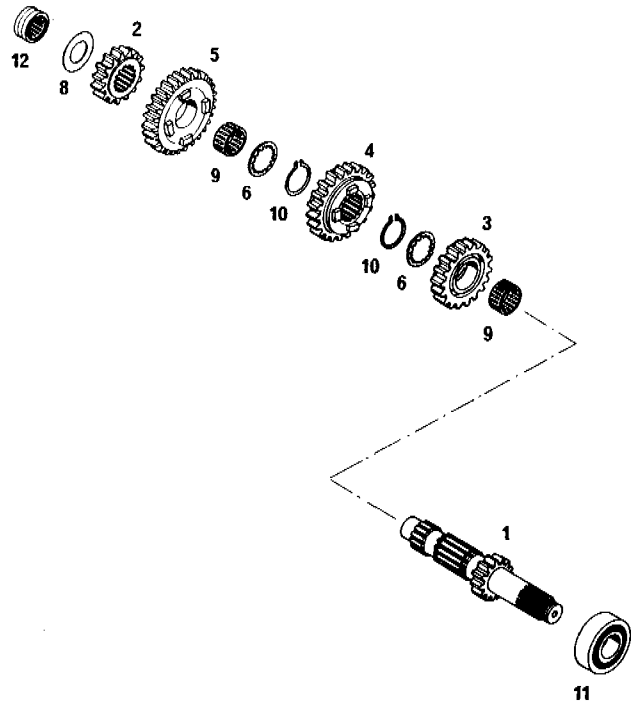

94-583.33.3 GETRIEBE II 350-620 LC4'94
TRANSMISSION II

BILD FIG.	TEILENUMMER PART NUMBER	BEZEICHNUNG DESCRIPTION	STK. QTY.
1	575.33.005.000	LOSRAD 1.G 33 Z (1M4) 1ST GEAR COUNTERS.	'93 1
2	565.33.013.400	LOSRAD 2.G 24 Z (2M4) 2ND GEAR COUNTERS.	1
2*	565.33.013.300	350-620 EGS/RXC, 400 EXC USA LOSRAD 2.G 24 Z (2G3) 2ND GEAR COUNTERS.	1
3	565.33.007.300	SCHIEBERAD 3.G 21 Z (3M3) 3RD GEAR COUNTERS.	1
4	565.33.009.300	LOSRAD 4.G 19 Z (4M3) 4TH GEAR MAINSH.	1
5	565.33.011.300	SCHIEBERAD 5.G 21 Z (5M3) 5TH GEAR COUNTERS.	1
6	580.33.003.100	ABTRIEBSWELLE COUNTER SHAFT	1
7	500.33.001.000	VERSCHLUSSPFROPFEN PLASTIC CAP	1
8	565.33.015.000	ANLAUFSCHIBE 20,2 X 35 X 1 THRUST WASHER	1
9	565.33.018.300	ANLAUFSCHIBE 22,2 X 35 X 1,5 THRUST WASHER	1
10	565.33.016.300	ANLAUFSCHIBE 22,7 X 32 X 1,5 THRUST WASHER	4
12	520.33.096.900	SPRENGRING 25 X 1,6 CIRCLIP	3
15	565.33.099.000	NADELKÄFIG K22X26X13 GETEILT NEEDLE CAGE	2
015	565.33.098.000	NADELKÄFIG K 22 X 26 X 13 NEEDLE CAGE	1
16	565.33.093.000	NADELLAGER RNA 4902 KSE NEEDLE BEARING	1
17	490.30.023.000	ZYLINDERROLLENLAGER NJ 205 ROLLER BEARING	1
19*	0770 250021	O-RING 2 X 25 SILICON O-RING	1
20	580.33.017.000	DISTANZBÜCHSE 25 X 32 X 9 SPACER BUSHING	1
21	0760 324771	WELLENDICHTRING 32X47X7 BSL SEAL RING	1
22	580.33.029.014	KETTENRAD 14 Z SPROCKET	1
22	580.33.029.015	KETTENRAD 15 Z SPROCKET	1
22	580.33.029.016	KETTENRAD 16 Z SPROCKET	1
23	510.33.031.000	SICHERUNGSBLECH LOCK WASHER	1
24	580.33.032.100	KETTENRADMUTTER LC4'91 SPROCKET NUT	1
25	580.33.030.000	DISTANZRING SPACER	1

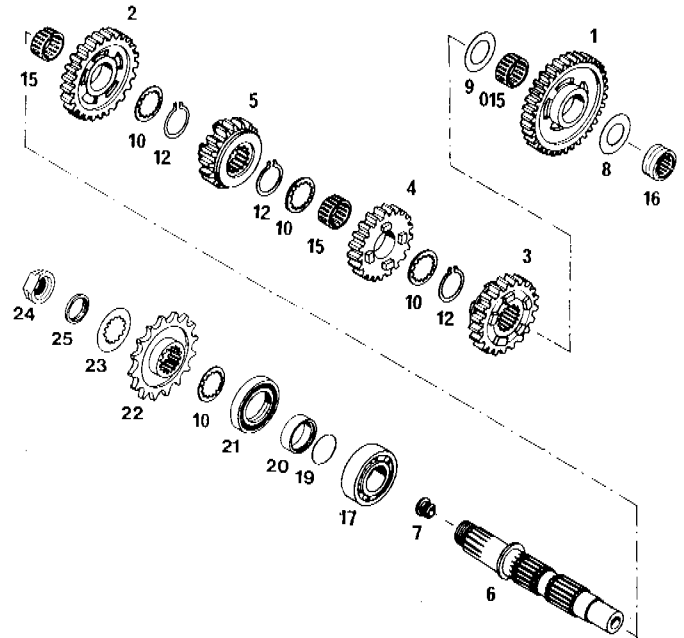

94-583.34.0 SCHALTUNG 350-620 LC4'94
SHIFTING MECHANISM

BILD FIG.	TEILENUMMER PART NUMBER	BEZEICHNUNG DESCRIPTION	STK. QTY.
1	580.34.005.344	SCHALTWELLE KPL. SHIFTING SHAFT CPL	'93 1
2	565.34.013.100	SPANNFEDER SPRING	1
3	580.34.010.000	STAHLSCHEIBE 14 X 28 X 2 WASHER	1
4	580.34.014.000	RÜCKHÖLFEDER RETURN SPRING	1
5	580.34.020.000	FEDERHÜLSE SPRING BUSHING	1
6*	0770 125020	O-RING 12,5 X 2 O-RING	2
7	580.33.027.000	V-DICHRING VA 0014 SEAL RING	1
10	580.34.002.100	SCHALTGABEL 1./4. U.2.G. SHIFT FORK 1/4 + 2	2
11	580.34.004.000	SCHALTSCHIENE 1/4 U 2 G SHIFTING ROD	1
12	580.34.001.100	SCHALTGABEL 3./5. GANG SHIFT.FORK 3RD/5TH	1
13	580.34.003.000	SCHALTSCHIENE 3./5. GANG SHIFTING ROD	1
14	0912 060553	ISK-SCHRAUBE DIN912-M6X55 A H BOLT	1
15	580.34.024.544	ARRETIERHEBEL KPL. LOCATING LEVER CPL	1
16	580.34.023.500	ARRETIERHEBELFEDER SPRING	1
17	580.34.017.500	ARRETIERFEDERHÜLSE BUSH	1
20	580.34.012.000	SCHALTWALZE 5 GANG SHIFTING DRUM	1
22*	501.34.026.100	NADELHÜLSE 30 X 37 X 7,5 NEEDLE CAGE	1
23	580.34.015.544	SCHALTARRETIERUNG KPL. SHIFT LOCAT. DRUM	1
24	0991 060303	SENKSCBRAUBE DIN7991-M6X30 SCREW	1
25	580.34.016.500	SCHALTKNOPF SHIFTING BUTTON	1
30	580.34.022.000	SCHALTHEBEL 4-TAKT KPL. SHIFTING LEVER	1
31	502.32.050.000	SCHEIBE 6,2 X 18 X 2 WASHER	1
32	0933 060163	SK-SCHRAUBE DIN933-M6X16 H H SCREW	1
33	502.33.041.000	NORDLOCK SCHEIBEN M6 (PAAR) PAIR OF WASHERS	1

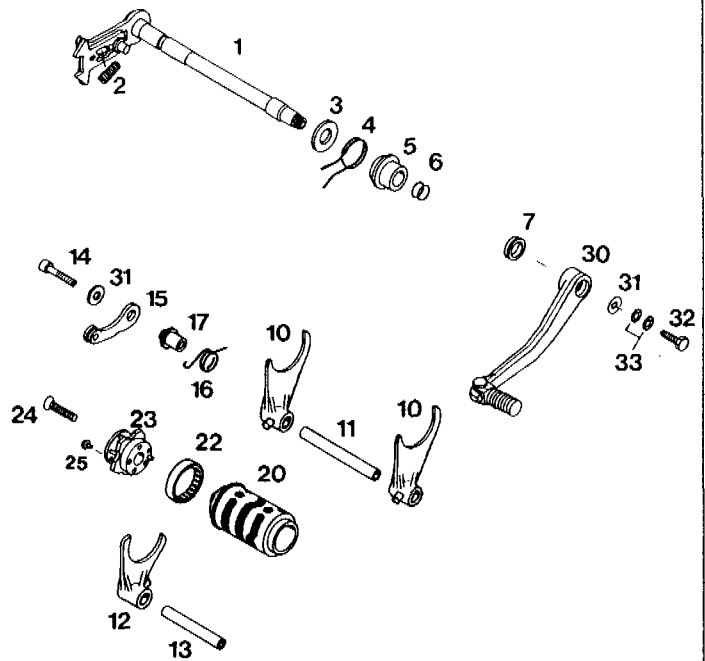

94-583.35.2 MECH. WASSERPUMPE LC4'94
 WATERPUMP M.DRIVEN

BILD FIG.	TEILENUMMER PART NUMBER	BEZEICHUNG DESCRIPTION	STK. QTY.
1	580.35.050.644	WASSERPUMPE MECHANISCH KPL '92 WATER PUMP CPL. AUSFÜHRUNG OHNE THERMOSTAT FOR TYPE WITHOUT THERMOSTAT	1
2	0471 120010	SEEGERRING DIN471-12X1 CIRCLIP	1
3	0472 280120	SEEGER-RING DIN472-28X1,2 SEEGER RING	1
4	0625 060016	RILLENKUGELLAGER 6001 RSR BEARING	2
5	0760 152472	WELLENDICHRING 15X24X7 A-DUO SEAL RING	1
6	544.35.010.000	WASSERPUMPENWELLE WATER PUMP SHAFT	1
7	0770 047015	O-RING 47 X 1,5 NBR 70 O-RING	1
8	580.35.002.600	WASSERPUMPENGEHÄUSE LOSE '92 WATER PUMP CASE	1
9	565.35.005.300	WASSERPUMPENRAD PUMP ROTOR	1
10	0021 050003	SCHEIBE DIN9021-A5,3 FLAT WASHER	1
11	0912 050123	ISK-SCHRAUBE DIN912-M5X12 A H SCREW	1
12	565.35.003.300	PUMPENDECKELDICHTUNG WATER PUMP GASKET	1
13	565.35.001.300	WASSERPUMPENDECKEL WATERPUMP COVER AUSFÜHRUNG OHNE THERMOSTAT FOR TYPE WITHOUT THERMOSTAT	1
14	0984 060203	ISK-SCHRAUBE DIN6912-M6X20 HH SCREW	4
15	580.36.065.000	DICHRING 6 X 10 X 1 CU SEAL RING	5
16	0912 060103	ISK-SCHRAUBE DIN912-M6X10 A H SCREW	1
19*	583.35.050.044	WASSERPUMPE MECHANISCH KPL. '94 WATER PUMP CPL. AUSFÜHRUNG MIT THERMOSTAT FOR TYPE WITH THERMOSTAT	1
20*	583.35.001.000	WASSERPUMPENDECKEL LC4'94 WATERPUMP COVER AUSFÜHRUNG MIT THERMOSTAT FOR TYPE WITH THERMOSTAT	1
21*	583.35.025.001	KÜHLERGEWEBESCHLAUCH 12 X 3 RADIATOR HOSE	1
22*	583.35.099.000	SCHLAUCHBINDER AES1 14-24 CLAMP	2
30*	583.35.013.044	THERMOSTAT KPL. 70 GRAD LC4'94 THERMOSTAT CPL.	1
31*	0770 320020	O-RING 32 X 2 O-RING	2
32*	583.35.017.000	THERMOSTAT 70 GRAD LC4'94 THERMOSTAT	1
33*	0770 021020	O-RING 21 X 2 NBR 70 O-RING	1
35*	0912 060453	ISK-SCHRAUBE DIN912-M6X45 A H BOLT	2

* = NEUTEILE / NEW PARTS X = NACH BEDARF / AS REQUIRED

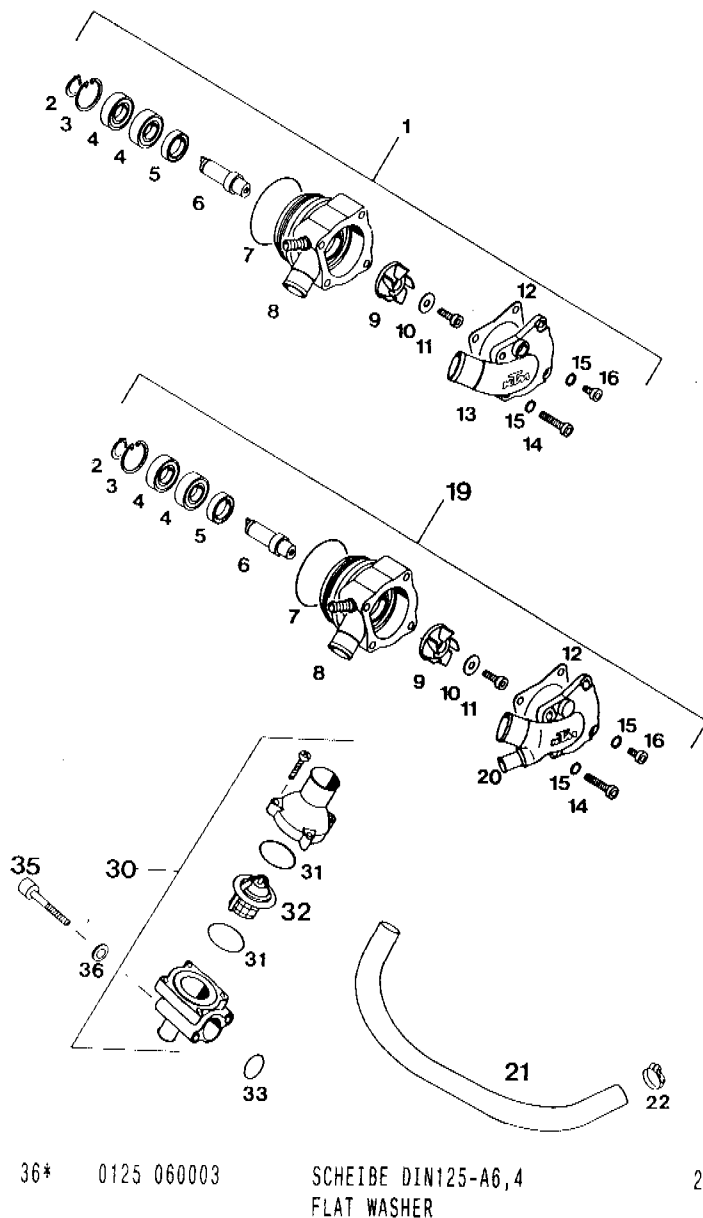

94-583.35.0 KÜHLSYSTEM 350-620 LC4'94
COOLING SYSTEM

BILD FIG.	TEILENUMMER PART NUMBER	BEZEICHNUNG DESCRIPTION	STK. QTY.
1	580.35.008.800	KÜHLER LINKS (45164) RADIATOR	'93 1
2	580.35.016.000	KÜHLERVERSCHLUSS KLEIN 1,4 BAR RADIATOR CAP	1
3	580.35.007.800	KÜHLER RECHTS LC4'93 (45174) RADIATOR R/S	1
4	580.35.134.000	KÜHLERSCHUTZ RECHTS FÜR LC4 PROTECTOR R/S	1
5	580.35.034.000	KÜHLERSCHUTZ LINKS FÜR LC4 PROTECTOR L/S	1
6*	502.35.033.300	KLIPS-MÜTTERNHALTER M6 KP142 SNAP NUT	4
7	565.35.025.001	KÜHLERSCHLAUCH 18X25 PER MET. RADIATOR HOSE	0,21
8	565.35.027.000	FORMSCHLAUCH 18X24-90GRAD RADIATOR HOSE	2
9	580.35.025.900	FORMSCHLAUCH 18 X 24 - 90GRAD PREF. RAD.HOSE	1
10	502.35.025.700	FORMSCHLAUCH PREF. RAD.HOSE	1
12	100.01.020.000	SCHLAUCHBINDER A2 CLAMP	12
13	544.35.024.001	ND-SCHLAUCH ID 7,5 PER METER HOSE	0,52
14	502.31.005.000	SCHLAUCHKLEMME - YDNAC 10119 CLAMP	4
15	550.07.016.001	SCHLAUCH 7X10 PER METER HOSE 7X10	0,31
16	440.11.076.155	KABELBAND 155MM PLASTIC BAND	X
20	410.01.052.000	KABELTÜLLE (INNENDURCHM.11MM) RUBBER SLEEVE	6
21	510.06.097.000	SCHEIBE 6,4 X 22 X 1 WASHER	6
22	546.35.022.000	TÜLLE-STEUERKOPF RUBBER SLEEVE	2
23	546.35.039.100	BUNDSCHRAUBE M6X10 SW=8 FLANGE BOLT	6
26	580.35.026.000	T-STÜCK 19/19/19 T-CONNECTOR	1
30	0908 140153	VERSCHLUSSSCHRAUBE M14X1,5 PLUG	1
31	0603 142015	DICHTRING 14 X 20 X 1,5 SEAL RING	1
35*	583.35.026.000	FORMSCHLAUCH RADIATOR HOSE	LC4'94 1

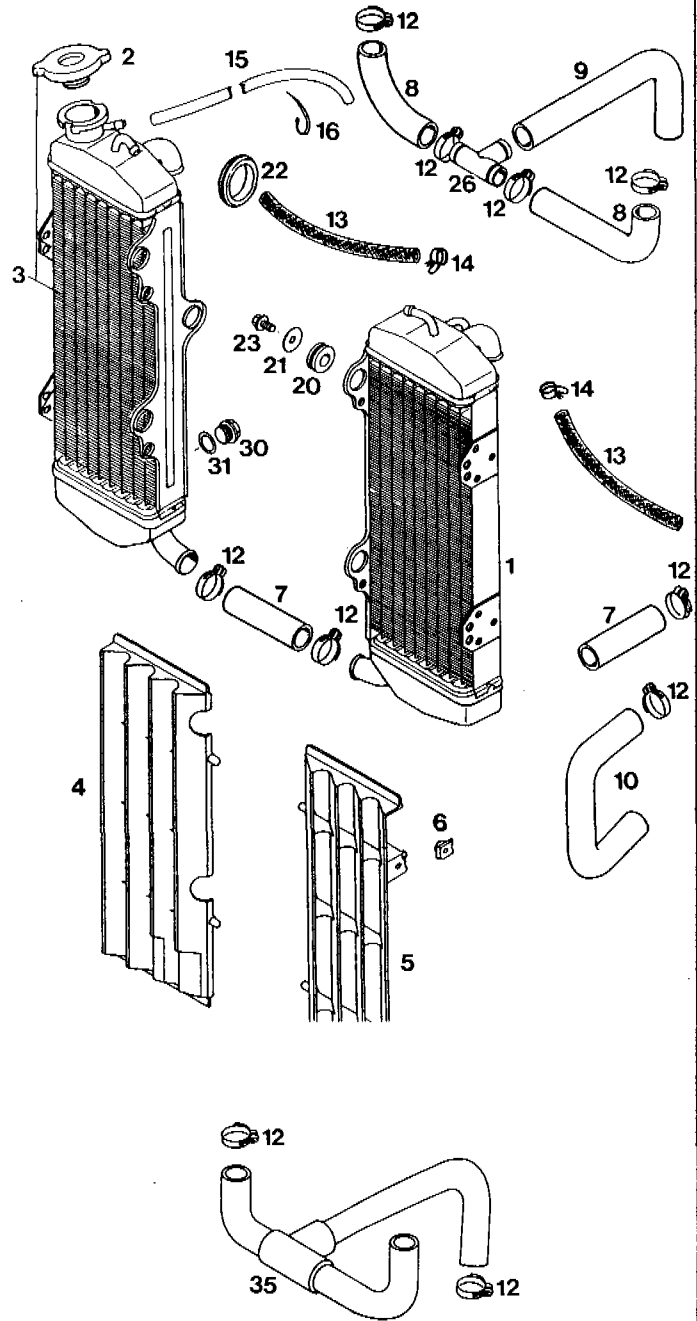

94-583.29.0 SPEZIALWERKZEUGE LC4'94
 SPECIAL TOOLS

BILD FIG.	TEILENUMMER PART NUMBER	BEZEICHUNG DESCRIPTION	STK. QTY.
1	580.12.001.000	MONTAGEBOCK REPAIR STAND	1
2	580.12.003.000	KUPPLUNGSHALTER 250-612 HOLDING PLATE	1
3	580.12.005.025	MONTAGEHÜLSE D=25MM GUIDE SLEEVE FÜR KURBELW.SIMMERRING LINKS FOR CRANKSHAFT SEAL L/S	1
4	580.12.009.000	SCHWUNGRADABZIEHER MAGNETO EXTRACTOR	1
5	510.12.016.000	SCHUTZKAPPE PROTECTION CAP	1
6	580.12.015.089	KOLBEN-MONTAGERING D=89MM PISTON RINGSPANNER 350 LC4	1
6	580.12.015.090	KOLBEN-MONTAGERING D=90MM PISTON RINGSPANNER 500 LC4	1
6	580.12.015.095	KOLBEN-MONTAGERING D=95MM PISTON RINGSPANNER 400/600 LC4	1
6	580.12.015.100	KOLBEN-MONTAGERING D=100MM PISTON RINGSPANNER 612 LC4	1
6	580.12.015.101	KOLBEN-MONTAGERING D=101MM PISTON RINGSPANNER 620 LC4	1
7	580.12.021.000	ABZIEHER EXTRACTOR F.PRIMÄRRAD U.KUPPL.MITNEHMER F.PRIM.GEAR D.INNER CLUTCHHUB	1
8	580.12.019.000	VENTIL-MONTAGEVORRICHTUNG VALVE MOUNTING SET	1
9	6 276 470	VENTILFEDER-SPANNEINSATZ PUSH INSERT	1
10	090.43	OMNIFIT 150 GRÜN OMNIFIT 150 GREEN	X
11	6899 785	LOCTITE BLAU 242 LOCTITE BLUE	6 CCM X
12	6 899 784	LOCTITE 574 ROT LOCTITE RED	50 CCM X
15	151.12.017.000	LAGERAUSZIEHER BEARING EXTRACTOR	1
16	151.12.018.000	EINSATZ 12-16 MM INTERN.BEAR.PULLER	1
16	151.12.018.100	EINSATZ 18-23 MM INTERN.BEAR.PULLER	1
20	580.30.080.000	FIXIERSCHRAUBE M8 LOCATING BOLT	1
20	510.12.012.000	HALTESCHLÜSSEL HOLDING SPANNER	1
26	580.29.026.007	GRENZLEHRDORN F. VENTILFÜHRUNG LIMIT PLUG GAUGE D=7,05MM	1

HOLZKLOTZ - SELBSTGEFERTIGT
 WOODEN BLOCK - HOME MADE

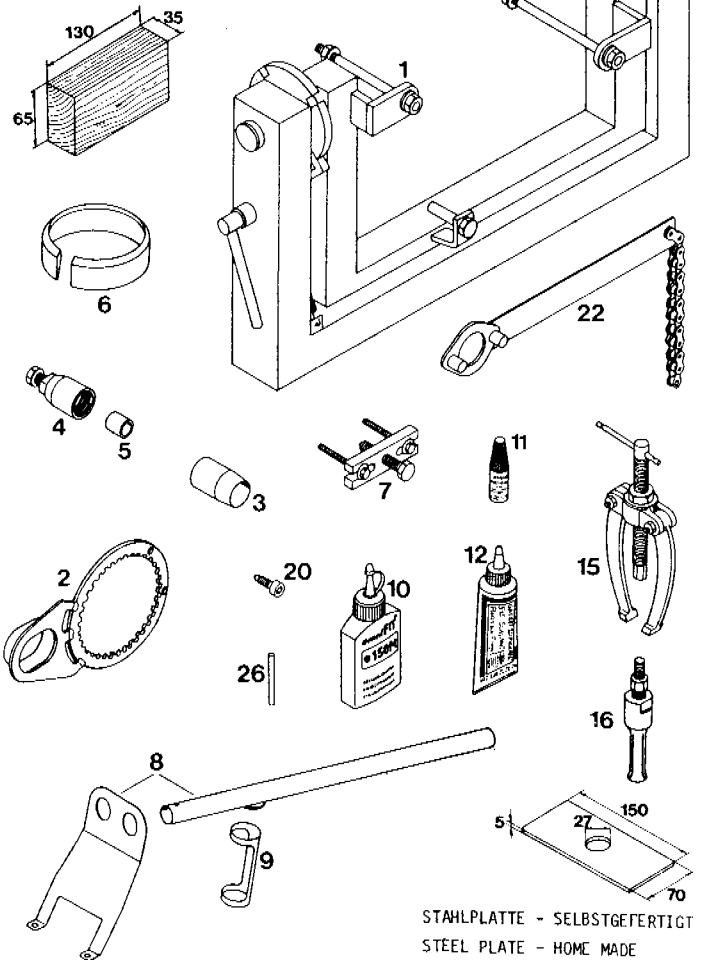

STAHLPLATTE - SELBSTGEFERTIGT
 STEEL PLATE - HOME MADE

TECHNISCHE DATEN - MOTOR

Motor	350 LC4	400 LC4	620 LC4
Bauart	1-Zylinder 4-Takt Otto-Motor, flüssigkeitsgekühlt		
Hubraum	349 cm ³	398 cm ³	609 cm ³
Bohrung/Hub	89 / 56,2 mm	95 / 56,2 mm	101 / 76 mm
Verdichtung	10,4 : 1	10,0 : 1	10,4 : 1
Kraftstoff	bleifreier Superkraftstoff mit mindestens ROZ 95		
Steuerung	4 Ventile über Kipphebel u. 1 Nockenwelle gesteuert, Antrieb der Nockenwelle mit Einfachkette		
Nockenwelle	Einlaß 249° Auslaß 225° [995] 249° [249]		
Steuerzeiten bei 1 mm	EÖ 17° v.OT AÖ 46° v.UT EÖ 14° v.OT AÖ 56° v.UT		
Ventilspiel	ES 52° n.UT AS 1° v.OT ES 52° n.UT AS 12° n.OT		
Ventildurchmesser	Einlaß: 36 mm Auslaß: 30 mm		
Ventilspiel kalt	Einlaß: 0,10 mm Auslaß: 0,10 mm		
Kurbelwellenlagerung	2 Zylinderrollenlager		
Pleuellager	Nadellager		
Kolbenbolzenlager	Bronzebüchse		
Kolben	Leichtmetall - geschmiedet Leichtmetall - gegossen		
Kolbenringe	1 Kompressionsring verchromt, 1 Minutiering, 1 Ölabschreifer		
Motorschmierung	Druckumlaufschmierung mittels Eatonpumpe		
Motoröl	vollsynthetisches Motoröl für 4-Takt Motoren von bekannten Marken (nach der Einfahrphase)		
Füllmenge Motoröl	Ölkreislauf nur im Motor: 1,7 Liter Ölkreislauf auch im Rahmen-Brustrohr: 2,4 Liter		
Primärtrieb	gerade verzahnte Stirnräder 30:81 Z		
Kupplung	Mehrscheibenkupplung im Ölbad		
Getriebe	5-Gang klauengeschaltet		
Zündanlage	kontaktlos gesteuerte Thyristor-Zündanlage mit elektronischer Zündverstellung, Typ SEM		
Zündzeitpunkt	Leerlauf: 6° v.OT (1200/min) - Verstellung ab 1700/min bis max. 38° v.OT bei 5000/min		
Generator	12V 130W		
Zündkerze	NGK D8EA		
Elektrodenabstand	0,6 mm		
Kühlung	Flüssigkeitskühlung, permanente Umwälzung der Kühllüssigkeit durch Wasserpumpe		
Kühlfüssigkeit	1 Liter, Mischungsverhältnis 40% Frostschutz, 60% Wasser, mindestens -25° C		
Starthilfe	Dekompressor handbetätigt, Kalt- und Warmstarteinrichtung am Vergaser		

VERGASER-GRUNDEINSTELLUNG

Vergasertyp	350 E-XC	400 E-XC	400 EGS	400/600 EGS	400 EGS	400 EGS	400 EGS	620 E-XC	620 E-XC	620 E-XC	620 E-XC
Regulierungsnummer	Competition	Super Compet	D	D	D, SGP	D	D	620 E-XC Comp	620 E-XC Su.Co	620 E-XC Su.Co	620 E-XC Su.Co
Hauptdüse	PHBE 36 HD 6835	PHBE 36 HD 6835/3	PHM 38 SD 4920	PHM 38 SD 4920/1CH	PHM 38 SD 4920/3	PHM 38 SD 4920/4	PHM 40 SD 4922	PHM 40 SD 4922/3	PHM 40 SD 4922/3	PHM 40 SD 4922/3	PHM 40 SD 4922/3
Nadeldüse	180	135	135	135	170	140	195	135	135	135	135
Leerdüse	DR 270	DR 268	DR 266	DR 266	DR 268	DR 268	DR 272	DR 268	DR 268	DR 268	DR 268
Düsenmodell	K 51	K 51	K 51	K 51	K 51	K 51	K 51	K 51	K 51	K 51	K 51
Nadelposition	2. von oben	2. von oben	2. von oben	2. von oben	3. von oben	3. von oben	2. von oben	3. von oben	3. von oben	3. von oben	3. von oben
Gemischreg. Schraube offen	1 Umdr.	1 - 1,5 Umdr.	2 Umdr.	2 Umdr.	1,5 Umdr.	1,5 Umdr.	1,5 Umdr.	1,5 Umdr.	1,5 Umdr.	1,5 Umdr.	1,5 Umdr.
Gasschieber	40	40	40	40	40	40	40	40	40	40	40
Startdüse	45	45	45	45	45	45	45	45	45	45	45

GETRIEBEÜBERSETZUNG

Primärübersetzung	Getriebeübersetzung	Originalübersetzung Hinterrad	Lieferbare Kettenritzel	Lieferbare Kettenräder hinten
30:81	SX	EGS	13 Z	40 Z
	EXC	RXC	14 Z für Kette	45 Z
	1. Gang	15:33	15:45	48 Z für Kette
	2. Gang	15:24	16:24	50 Z $\frac{5}{8} \times \frac{1}{8}$
	3. Gang	18:21	18:21	52 Z
4. Gang	20:19	20:19	16 Z	
5. Gang	27:21	27:21	RXC	16:45

TOLERANZEN, EINBAUSPIELE

Kurbelwelle	Axialspiel.....	0,1 - 0,2 mm
	Kurbelzapfenschlag.....	max. 0,04 mm
Pleuellager	Radialspiel.....	max. 0,05 mm
	Axialspiel.....	max. 1,00 mm
Kolben	Einbauspil 350/400/620.....	max. 0,12 mm
Kolbenringe Stoßspiel	Kompressionsringe.....	max. 0,60 mm
	Ölabschreifer.....	max. 0,80 mm
Ventile	Dichtsbreite Einlaß.....	max. 1,50 mm
	Auslaß.....	max. 2,00 mm
	Ventilteller Schlag.....	max. 0,03 mm
	Ventilführung Durchmesser.....	max. 7,05 mm
Ölpumpe	Spiel Außenrotor - Gehäuse.....	max. 0,20 mm
	Spitzenspiel Außen- Innenrotor.....	max. 0,20 mm
Bypaßventil	Druckfeder Mindestlänge.....	25 mm
Kupplungslamellen	Mindeststärke Organisch.....	2,8 mm
Getriebewellen	Axialspiel.....	0,1 - 0,3 mm

ANZUGSDREHMOMENTE - MOTOR

Sechskantmutter Primärtrrad	M20x1,5	Loctite + 170Nim
Bundmutter Schwungrad	M12x1 links	60 Nim
Sechskantmutter für Kupplungsmittelnemer	M18x1,5	80 Nim
Kickstarter-Anschlagschraube	M12x1,5	70 Nim
Innensechskantschrauben der Ölpumpen	M6	8 Nim
Sechskantschraube Nockenwellenrad	M10	50 Nim
Schrauben Zylinderkopf-Oberteil	M6	8 Nim
Zylinderkopfschrauben	M10	50 Nim
Bundmutter am Zylinderfuß	M10	40 Nim
Sechskantmutter Kettenrad	M20x1,5	70 Nim
Ölabschraube	M22x1,5	50 Nim
Magnetschraube	M12x1,5	20 Nim
Verschlußschraube Bypaßventil	M12x1,5	20 Nim
Hohlsschrauben Ölleitungen	M8	10 Nim
Hohlsschrauben Ölleitungen	M12	20 Nim
Verschlußschraube Steuerkettenspanner	M12x1,5	20 Nim
Kontermutter Ventilfeststellschrauben	M7x0,75	20 Nim

TECHNICAL DATA - ENGINE

Engine	350 LC4	400 LC4	620 LC4
Design	Liquid-cooled single cylinder 4-stroke engine		
Displacement	349 cm ³	398 cm ³	609 cm ³
Bore / Stroke	89 / 56,2 mm	95 / 56,2 mm	101 / 76 mm
Ratio	10,4 : 1	10,0 : 1	10,4 : 1
Fuel	unleaded premium gasoline with a least RON 95		
Valve timing	4 valves over rocker arm and 1 overhead camshaft, camshaft drive through single chain		
Camshaft	Intake: 249° Exhaust: 225° (995) 249° (249)		
Valve timing by 1 mm valve clearance	IO 17° BTDC EO 46° BBDC IO 14° BTDC EO 56° BBDC IC 52° ABDC EC 1° BTDC IC 52° ABDC EC 12° ATDC		
Valve diameter	Intake: 36 mm Exhaust: 30 mm		
Valve clearance cold	Intake: 0,10 mm Exhaust: 0,10 mm		
Crank shaft bearing	2 cylinder roller bearing		
Connecting rod bearing	needle bearing		
Top end bearing	bronze bushing		
Piston	forged aluminium-alloy		
Piston rings	1 compression ring, 1 taper face ring, 1 oil scraper ring cast aluminium alloy		
Engine lubrication	forced-feed lubrication through Eaton-Oilpump with oil sump		
Engine oil	fully synthetic recommended brand multi-grade engine oil for 4-stroke engine (after running in)		
Engine oil quantity	oil flow also thru engine: 1,7 liters oil flow also thru main frame tube: 2,4 liters		
Primary ratio	straight geared spur wheels 30 : 81 teeth		
Clutch	multi disc clutch in oil bath		
Transmission	5-speed claw shifted		
Ignition system	contactless thyristor ignition with electronic advanced system type SEM		
Ignition timing	idling: 6° BTDC (1200 rpm) - adjustment from 1700 rpm to max. 38° BTDC at 5000 rpm		
Generator	12V 130W		
Spark plug	NGK D8EA		
Spark plug gap	0,6 mm		
Cooling system	liquid cooled, permanent rotation of cooling liquid through mechanic driven water pump		
Cooling liquid	1 liter, 40% antifreeze, 60% water, at least -25° C (-13° F)		
Starting equipment	decompressor hand actuated, cold and warm start knob on carburetor		

BASIC CARBURETOR SETTING

Type	350 EXC		400 EXC		400 EXC Comp.		620 SX		620 RXC		620 EVC 20kW		620 EGS 20kW	
	PHBE 36 HD	6635	PHM 38 SD	4920	PHM 38 SD	4894/6	PHM 40 SD	4922	PHM 40 SD	4922/2	PHM 40 SD	4922/3	PHM 40 SD	4922/3 CH
Carburetor setting number	180	DR 270	170	DR 268	190	DR 270	170	DR 268	170	DR 268	135	DR 268	135	DR 268
Main jet	52	K 51	45	K 51	45	K 51	45	K 51	45	K 51	45	K 51	45	K 51
Needle jet	2nd	2nd	3rd	2nd	2nd	3rd	3rd	3rd	3rd	3rd	3rd	3rd	3rd	3rd
Idling jet	1 turn	40	1,5 turn	1,5 turn	1,5 turn	1,5 turn	1,5 turn	1,5 turn	1,5 turn	1,5 turn	1,5 turn	1,5 turn	1,5 turn	1,5 turn
Jet needle	45	45	45	45	45	45	45	45	45	45	45	45	45	45
Needle clip position from top														
Mixture adjusting screw open														
Throttle valve														
Starting jet														

GEAR RATIOS

Primary ratio	Transmission	Original final drive ratio	Available chain drive sprockets	Available final drive sprockets
30:81	SX	15:50		
	EGS	15:50		
	RXC	15:50		
	EXC	15:50	40 t	40 t
	EXC	15:50	45 t	45 t
1st Gear	15:33	16:40	13 t	for chain
2nd Gear	15:24	16:24	14 t	for chain
3rd Gear	18:21	18:21	15 t	5/8 x 1/8"
4th Gear	20:19	20:19	16 t	5/8 x 1/8"
5th Gear	27:21	27:21	RXC	52 t

TOLERANCE, ASSEMBLY CLEARANCE

Crank shaft	axial play	0,1 - 0,2 mm
	run out of crank stud	max. 0,04 mm
Connecting rod bearing radial play		max. 0,05 mm
	axial play	max. 1,00 mm
Piston	assembly clearance 350/400/620	max. 0,12 mm
Piston rings end gap	compression rings	max. 0,60 mm
	oil scraper ring	max. 0,80 mm
Valves	seat sealing intake	max. 1,50 mm
	seat sealing exhaust	max. 2,00 mm
	run out of valve heads	max. 0,03 mm
	valve guides diameter	max. 7,05 mm
Oil pump	clearance outer rotor - housing	max. 0,20 mm
	clearance outer rotor - inner rotor	max. 0,20 mm
Bypass valve	minimum spring length	25 mm
Clutch discs	wear limit organic	2,8 mm
Transmission shafts	axial play	0,1 - 0,3 mm

TIGHTENING TORQUES - ENGINE

Hexagon nut at primary gear	M20x1,5	Loctite + 170Nm
Collar nut flywheel	M12x1 IH thread	60 Nm
Hexagon nut for inner clutch hub	M18x1,5	80 Nm
Kickstarter stop screw	M12x1,5	70 Nm
Allen head screws oil pump	M6	8 Nm
Hexagon screw camshaft gear	M10	50 Nm
Allen head screw cylinder head top sect.	M6	8 Nm
Cylinder head screws	M10	50 Nm
Collar nuts at cylinder base	M10	40 Nm
Hexagon nut chain sprocket	M20x1,5	70 Nm
Oil drain plug	M22x1,5	50 Nm
Magnetic plug	M12x1,5	20 Nm
Plug bypass valve	M12x1,5	20 Nm
Hollow screws oil lines	M8	10 Nm
Hollow screws oil lines	M12	20 Nm
Screw plug timing-chain tensioner	M12x1,5	20 Nm
Counternuts valve adjusting screws	M7x0,75	20 Nm

KTM-SPORTMOTORCYCLE GESELLSCHAFT M.B.H.
A-5230 Mattighofen • Postfach 66 • Austria
Tel. 07742/3152-0 • Telefax 07742/3152-7
HRB 751 - Handelsgericht Ried im Innkreis